



# KEX-20 E      KEX-23 E

**ARC TUNER** COMPONENT CAR STEREO  
CASSETTE DECK  
WITH AM/FM ELECTRONIC TUNER

**ARC TUNER** COMPONENT CAR STEREO  
CASSETTE DECK  
WITH LW/MW/FM ELECTRONIC TUNER

## SERVICE MANUAL



Free service manuals  
Gratis schema's  
Digitized by

www.freeservicemanuals.info



### Subject:

For Cassette Mechanism, refer to the Service Manual of unit number CX-100A/H

## SPECIFICATIONS

### General

Power source . . . . . DC 13.8V (11 ~ 16V allowable)  
Grounding system . . . . . Negative type  
Tone controls . . . . . Bass:  $\pm 10$  dB (100 Hz)  
Treble:  $\pm 10$  dB (10 kHz)  
Maximum output level . . . . . More than 200mV  
Output impedance . . . . . 100 $\Omega$   
Dimensions (W x H x D) . . . . . 180 x 50 x 150 mm  
Nose size (W x H x D) . . . . . 105 x 42 x 16 mm  
Shaft interval . . . . . 130 mm  
Weight . . . . . 1.7 kg

### Tape player

Tape . . . . . Compact cassette tape (C-30 ~ C-90)  
Tape speed . . . . . 4.76 cm/sec. (+ 0.19 cm/sec. - 0.05 cm/sec.)  
Fast forward time . . . . . Within 120 sec. for C-60  
Rewind time . . . . . Within 120 sec. for C-60  
Wow & flutter . . . . . No more than 0.13% (WRMS)  
Frequency response . . . . . 30 ~ 15,000 Hz ( $\pm 3$  dB)  
Cross talk . . . . . More than 46 dB  
Signal-to-noise ratio . . . . . Dolby NR IN: more than 60 dB  
Dolby NR OUT: more than 52 dB

### FM tuner

Frequency range . . . . . 88 ~ 108 MHz (KEX-20)  
88 ~ 104 MHz (KEX-23)  
Usable sensitivity . . . . . 13.8 dBf (1.9  $\mu$ V/150 $\Omega$ )  
50 dB quieting sensitivity . . . . . 17.5 dBf (2.9  $\mu$ V/150 $\Omega$ , mono)  
39.8 dBf (38  $\mu$ V/150 $\Omega$ , stereo)

Signal-to-noise ratio . . . . . 60 dB  
Capture ratio . . . . . 1.5 dB  
Selectivity . . . . . 70 dB ( $\pm 400$  kHz)  
Image rejection . . . . . 45 dB  
IF rejection . . . . . 80 dB  
Distortion . . . . . 0.5% (at 60 dB, 400 Hz, mono)  
0.5% (at 60 dB, 1 kHz, stereo)  
Frequency response . . . . . 30 ~ 15,000 Hz ( $\pm 3$  dB)  
Muting level . . . . . 17.5 dBf (2.9  $\mu$ V/150 $\Omega$ )  
Stereo separation . . . . . 32 dB (at 60 dB, 1 kHz)

### MW (AM) tuner

Frequency range . . . . . 525 ~ 1,605 kHz  
Sensitivity . . . . . 30  $\mu$ V  
Selectivity . . . . . 25 dB ( $\pm 10$  kHz)  
Local/distant switch effect . . . . . 14 dB attenuation  
Max. input signal (distortion 5%) . . . . . 125 dB

### LW tuner (KEX-23 only)

Frequency range . . . . . 150. ~ 280 kHz  
Sensitivity . . . . . 70  $\mu$ V  
Selectivity . . . . . 35 dB ( $\pm 10$  kHz)  
Local/distant switch effect . . . . . 14 dB attenuation  
Max. input signal (distortion 5%) . . . . . 125 dB

### Note:

Specifications and the design subject to possible modification without notice due to improvements.

# PIONEER®

# CONTENTS

1. PARTS LOCATION .....	1
2. CIRCUIT DESCRIPTION .....	1
3. ADJUSTMENT	
3.1 FM IF Adjustment .....	9
3.2 IF/MPX Adjustment .....	9
3.3 Auto Level Adjustment .....	9
3.4 FM Tracking Adjustment .....	10
3.5 AM IF Adjustment (KEX-20) .....	11
3.6 AM Tracking Adjustment (KEX-20) .....	12
3.7 MW/LW IF Adjustment (KEX-23) .....	13
3.8 MW/LW Tracking Adjustment (KEX-23) .....	14
3.9 Dolby NR Law Adjustment .....	15
3.10 Dolby NR Level Adjustment .....	16
4. SCHEMATIC CIRCUIT DIAGRAM (KEX-20) .....	19
5. CONNECTION DIAGRAM (KEX-20) .....	23
6. SCHEMATIC CIRCUIT DIAGRAM (KEX-23) .....	27
7. CONNECTION DIAGRAM (KEX-23) .....	31
8. CABINET EXPLODED VIEW .....	35
9. CHASSIS EXPLODED VIEW .....	36
10. PACKING METHOD .....	38
11. PARTS LIST .....	39

\*The word "Dolby" and  are trademarks of Dolby Laboratories.

# 1. PARTS LOCATION KEX-20 KEX-23

• The photo shows the model KEX-23.

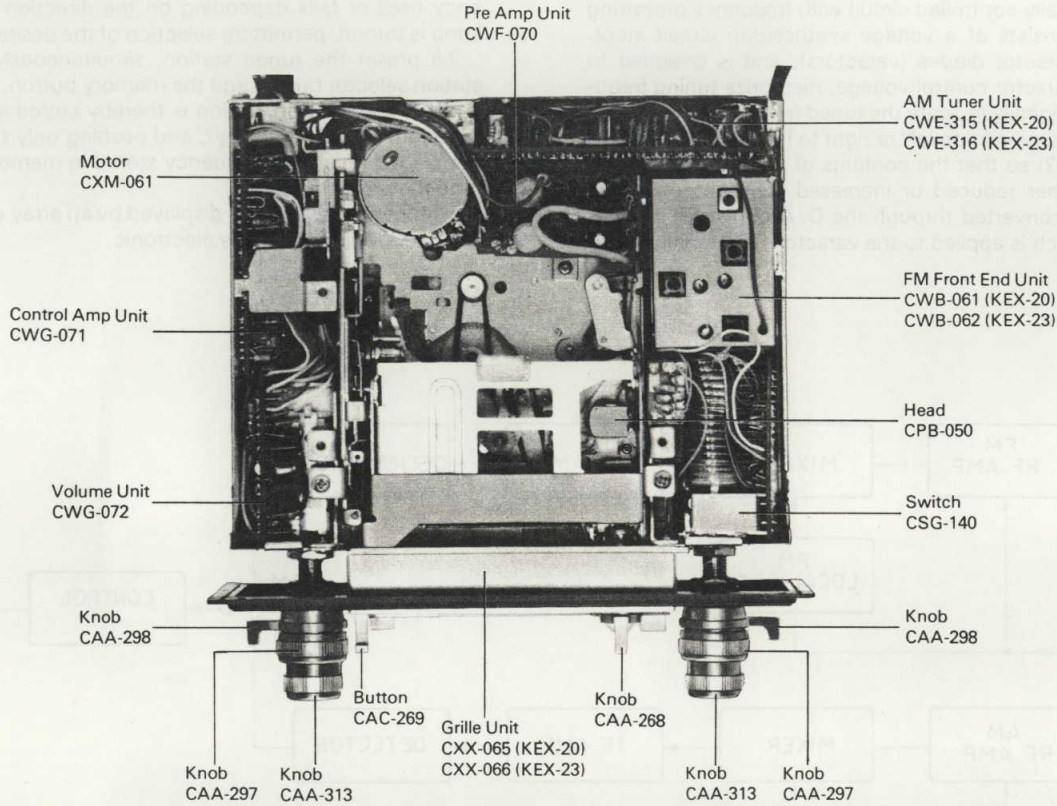

Fig. 1

# 2. CIRCUIT DESCRIPTION

• Audio Level Diagram

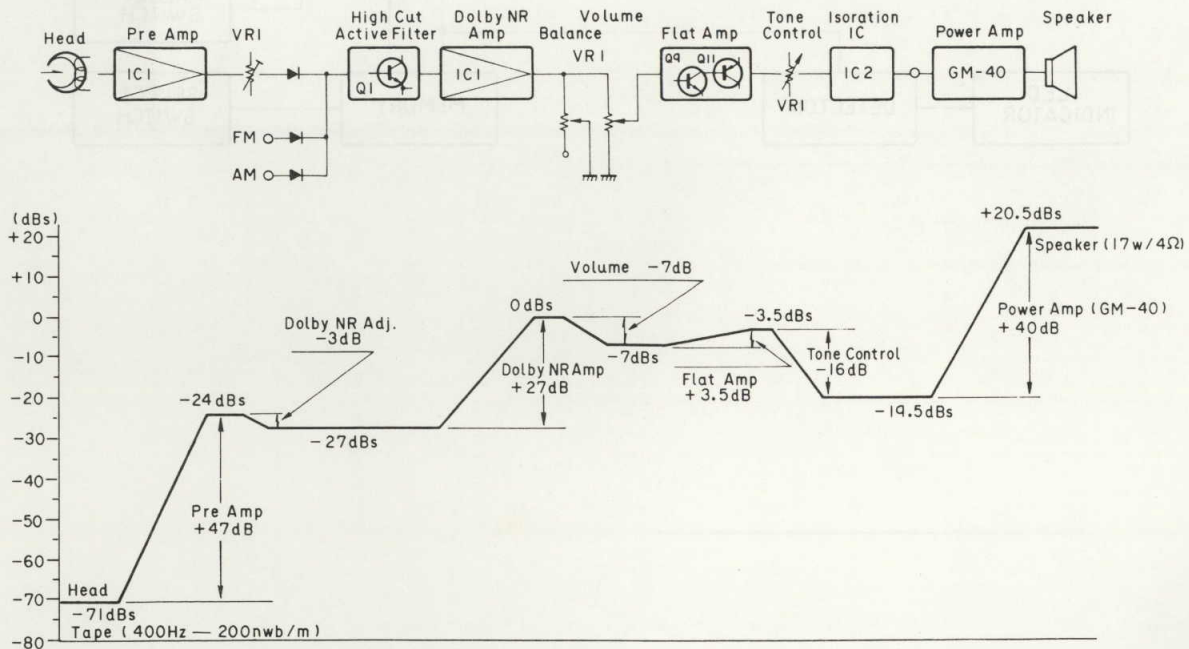

Fig. 2

## CIRCUIT DESCRIPTION

### • Digitally Controlled Preset Tuner

This digitally controlled circuit with frequency presetting systems consists of a voltage synthesizing circuit incorporating varactor diodes (varactors), and is designed to generate varactor control voltage, memorize tuning frequency, and digitally indicate the tuned frequency.

Turn the tuning knob left or right to feed tuning pulses to LSI (PD1002) so that the contents of the internal counter may be either reduced or increased. The output of the counter is converted through the D/A converter into DC voltage which is applied to the varactor. The tuning frequency

risks or falls depending on the direction the tuning knob is turned, permitting selection of the desired stations.

To preset the tuned station, simultaneously push the station selector button and the memory button. The frequency of the selected station is thereby stored in the RAM (Random Access Memory), and pushing only the selector button will recall the frequency stored in memory to again tune the preset station.

The frequency tuned is displayed by an array of 32 LEDs. This readout is completely electronic.

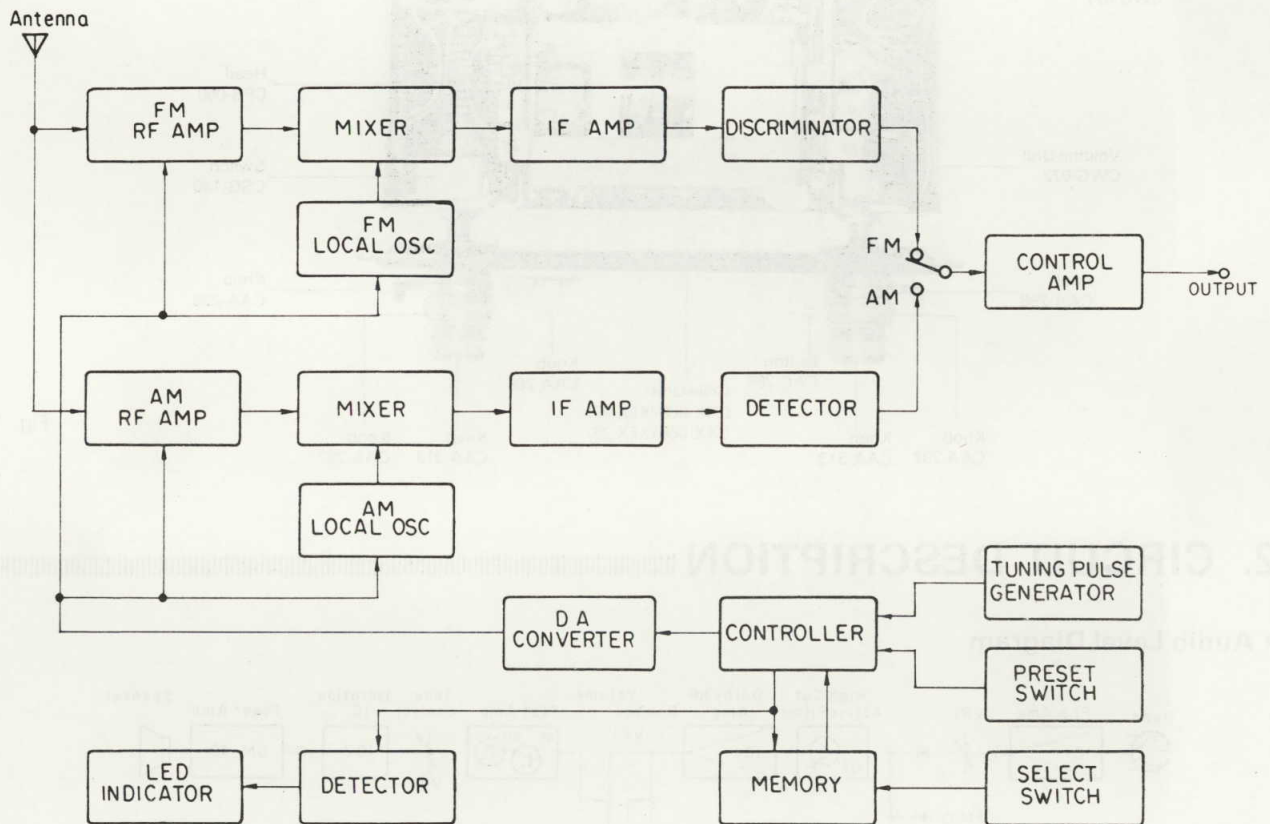

Fig. 3

• Control LSI (PD 1002)

The block diagram of LSI PD1002 is shown in Fig. 4. The essential function here is represented by the 11 bit up/down counter, the output of each bit being connected to a D/A converter in order to generate a DC voltage corresponding to the contents of the counter. The contents of this counter is variable by means of applying externally generated tuning pulses so that the desired voltage output level can be obtained. Each bit, moreover, is connected with the RAM (Random Access Memory) so that the output voltage of the tuned frequency can be stored in order that station presetting can be performed. This process is via digital signals. And, of course, this stored information can be recalled instantly to the counter to allow tuning of

the memorized preset station frequency.

Because semiconductor memories are volatile—that is, memory disappears with removal of supply voltage—voltage must continue to the memory portions of the circuit even with power OFF. The CMOS PD1002, however, requires extremely low levels of power: with the oscillator not in operation power consumption is only several tens  $\mu$ W; with the oscillator in operation the power consumption is 20mW. Therefore, with the oscillator not in operation, connection of the PD1002 poses no problem to car batteries. In other words, with the enable terminal at low levels there is no oscillation, and the terminal is designed to be at low levels with the power supply switch set to OFF.

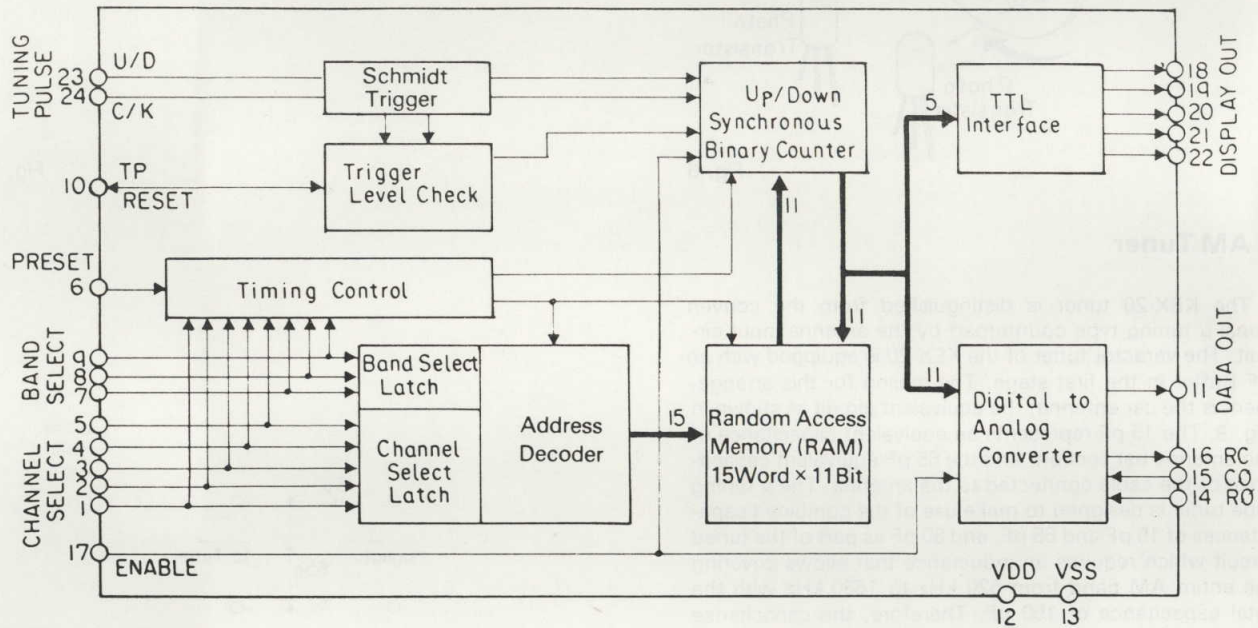

Fig. 4

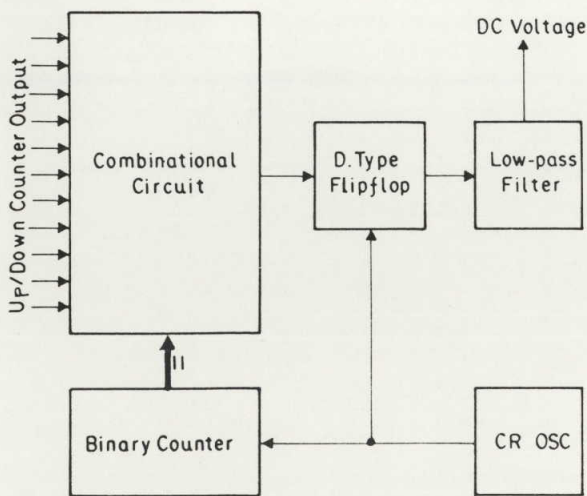
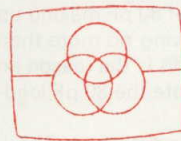

Fig. 5



Free service manuals  
Gratis schema's  
Digitized by

www.freeservicemanuals.info

## CIRCUIT DESCRIPTION

## • Tuning Pulse Generator

This device (basic operating principles are shown in Fig. 6) generates up/down pulses and clock pulse by turning the tuning knob. The direction the disc is turned deter-

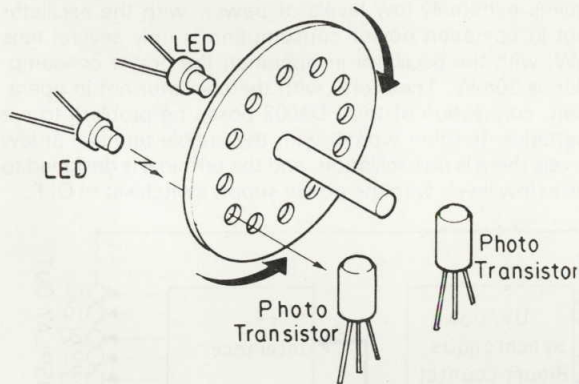

Fig. 6

mines whether up or down pulses are generated (see Fig. 7). These pulses determine the contents of the up/down counter.

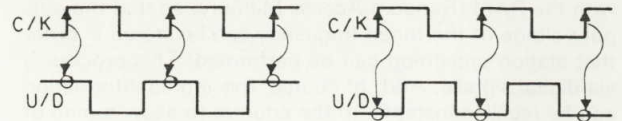

Fig. 7

## • AM Tuner

The KEX-20 tuner is distinguished from the conventional  $\mu$  tuning type counterpart by the antenna input circuit. The varactor tuner of the KEX-20 is equipped with an RF Buffer in the first stage. The reason for this arrangement is the car antenna, the equivalent circuit as shown in Fig. 8. The 15 pF represents an equivalent capacitance of the antenna bar section, and the 65 pF equivalent capacitance of the cable connected to the antenna. The  $\mu$  tuning type tuner is designed to make use of the combined capacitances of 15 pF and 65 pF, and 80 pF as part of the tuned circuit which requires an inductance that allows covering the entire AM band from 520 kHz to 1630 kHz with the total capacitance of 150 pF. Therefore, the capacitance variation ratio is  $(1630 \div 520)^2 = 9.83$ . The voltage to be applied to the varactor is in the range 1.4V to 8.4V. The standard SVC-303 provides a capacitance of 417 pF for 1.4 V and 24.48 pF for 8.4 V, and the variation ratio being 18.24. This means the band ranging from 520 kHz to 1630 kHz can be adequately covered.

The varactor, however, if used in the input circuit, will result in a capacitance variation ratio of  $(417 + 80) \div (24.48 + 80) = 4.76$  with the addition of 80 pF making up the equivalent antenna circuit and allowing no more than half the required band to be covered. This is the reason an RF buffer amplifier is required to eliminate the 80 pF loading capacitance.

The varactor tuner has yet another advantage. The  $\mu$  tuning type tuner requires adjustment of sensitivity when tuning in a weak signal around 1 MHz in order to prevent tracking error due to the difference in capacitance in the antenna cable. The varactor tuner eliminates this problem.

Q1 (2SK49) directly connected to the antenna is most vulnerable to surging, and D1 (ITT73N) is placed between the input terminal and ground to absorb it. ITT73N is rated at 1A per second. The input section of the FM tuner connected in parallel to the antenna input terminal incorporates a discharge element with a firing potential of less than 2 kV.

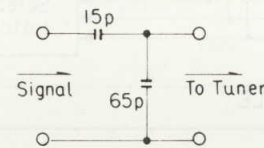

Fig. 8

### • Oscillator Circuit

Fig. 9 shows the tuning voltage supply circuit and the varactor temperature compensating circuit. Adjusted for the dispersion properties of the varactor, the working voltage is made variable so as to permit adjustment of the band to be covered. E1 is a tuning variable power supply, E2 is a stabilized power supply of 8.8 V, and R1 is a resistor for the filter incorporated in the output section of the control IC (PD1002). The control IC is driven via the same voltage as E2 so that the maximum voltage of E1 is 8.8 V, and the maximum voltage to be applied to the varactor cathode, regardless of the volume position, is 8.8 V. The minimum voltage with E1 at 0 V is determined by the values of E2, R1, R2, and VR1; and the minimum voltage is designed to be 1.8 V with the standard varactor.

The anode side of the varactor is equipped with a temperature compensating circuit which is composed of varistors and resistors. The anode electric potential is 0.4 V, and the voltage to be applied to either end of the varactor is 1.4 V to 8.4 V. The capacitance compensating voltage to match the change in the temperature of the varactor varies with the working voltage from 1.1 mV/°C. The voltage variation of the varistor MV-1 is -2mV/°C, and the anode side of the varistor, will lead to overcompensation. Therefore, the variation in voltage of the varactor is divided through resistors R4 and R5 to provide a voltage change of some -1.3 mV/°C. R3, a biasing resistor for the varistor, is designed to supply 3 mA.

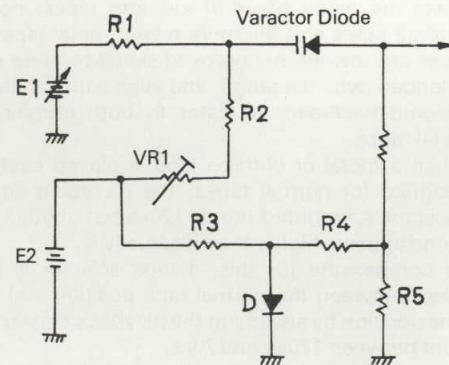

Fig. 9

### • LW/MW Tuner

An LW/MW tuner should be able to tune the two bands (MW: 515 — 1,630kHz; LW: 145 — 295kHz). Therefore, the LW/MW tuner has two different types of applied voltages for the variable capacitor, high frequency circuits, and oscillator circuits which should be switched for MW and LW. For the applied voltages of the variable capacitor, the independent volumes for MW and LW are mounted on this tuner for adjusting the applied voltages, and the voltages to be applied are changed with a mechanical switch. For the high frequency circuits, the coil for MW is connected to that for LW in a series. While the MW is being tuned, the coil for LW is shortcircuited; while the LW is being tuned, the high frequency circuits are changed with a switch diode so that both the coils for MW and LW may be worked as the tuning coil for LW. For the oscillator circuits, independent oscillator circuits for MW and LW are incorporated in the tuner and are changed with a switch diode.

## CIRCUIT DESCRIPTION

### • Tape Selector Circuit

There are many types of cassette tapes: normal tapes, chrome tapes and the more recent metal tapes. Trends in tapes are toward an improved signal-to-noise ratio and an extended dynamic range, and even with car stereos, it has become necessary to cater to both chrome tapes and metal tapes.

When a metal or chrome tape is played back on a deck designed for normal tapes, the recording equalizer time constant is recorded not at  $120\mu\text{s}$  but at  $70\mu\text{s}$ , and so the sound appears higher than it actually is.

To compensate for this, a tape selector is provided to select between the normal tape position and the chrome tape position by switching the playback equalizer time constant between  $120\mu\text{s}$  and  $70\mu\text{s}$ .

When this switch is set to the normal tape position (tape selector is OFF), the output level falls as the frequency rises from about 50 Hz ( $3180\mu\text{s}$ ) at  $-6\text{ dB/oct}$ , and when the frequency rises above the 1.3 kHz ( $120\mu\text{s}$ ) level, the level becomes constant—this is the NAB curve (Fig. 10). Usually, when playing back a normal tape, the frequency response is flat. But when a chrome tape or a metal tape is played back with this switch at the normal position, the high frequency range response rises several dB.

When the switch is set to the chrome tape position (tape selector is ON), the low-frequency range response is the same as that for the normal position but the level drops around a frequency of about 2.3 kHz ( $70\mu\text{s}$ ) at  $-6\text{ dB/oct}$ , and once the frequency exceeds this value, the level becomes constant. When a chrome tape or a metal tape is played back, the frequency response becomes flat. When playing back a normal tape in the chrome position, the high frequency range response falls several dB.

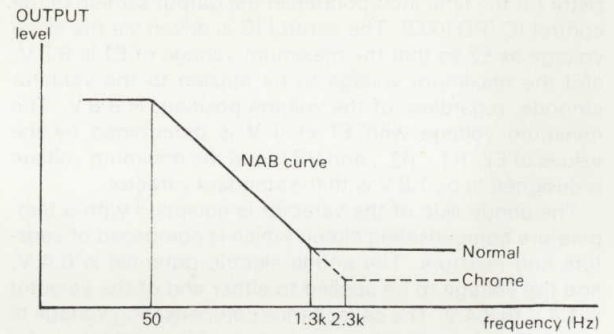

Fig. 10

## CIRCUIT DESCRIPTION

KEX-20  
KEX-23• **Dolby NR Circuit**

Dolby NR is a method of reducing tape hiss, particularly the noise heard in the high-frequency region, and its circuit improves the signal-to-noise ratio by about 10dB. The Dolby NR circuit works as a flat amplifier during AM or FM reception and during ordinary tape playback, and it provides the Dolby NR effect when the Dolby NR switch is set to the IN position during the playback of a tape which has been recorded using the Dolby NR system.

In the case of the left channel, the signal which has passed through the D1, D3 or D5 signal selector diode passes through the 19kHz high cut filter and is amplified by Q3. The Dolby NR circuit employs IC1(HA11226) which is provided in both the left and the right channels.

When the Dolby NR switch is set to the OUT position, + B is applied as bias to the base of Q5 and Q5 goes to OFF. Since this prevents the signal from entering the high-pass filter of the Dolby NR circuit, this circuit functions as an ordinary flat amplifier.

When the Dolby NR switch is set to the IN position, + B is not supplied to Q5 and Q5 goes to ON. The high-pass filter of the Dolby NR circuit is therefore connected to the output terminals and the Dolby NR effect is provided.

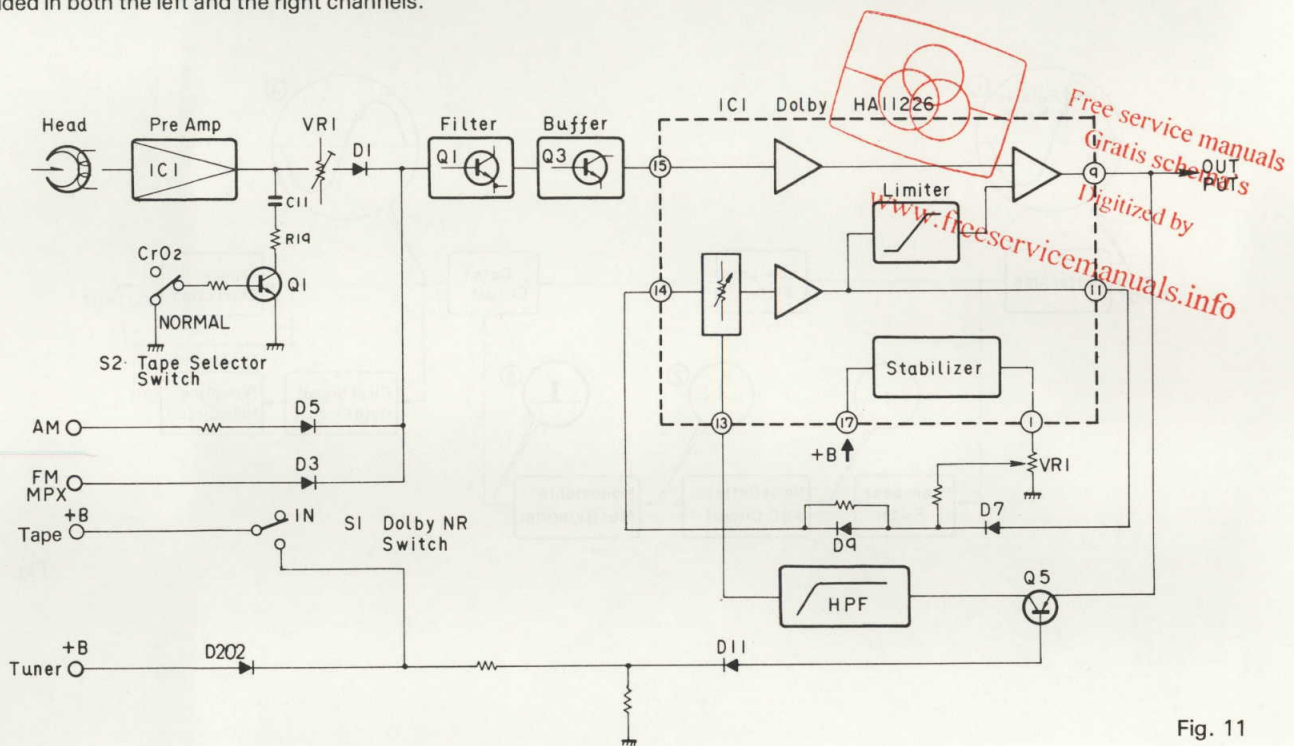

Fig. 11

## CIRCUIT DESCRIPTION

### • Noise Suppressor

The input signal containing the pulsive noise as illustrated in Waveform-1 is first impedance-converted by the buffer amplifier, then coupled to the gate circuit via the low-pass filter.

Meanwhile, the high-pass filter filters out only the pulsive noise component from the input signal and feeds the noise component to the noise detector where it is amplified and rectified. (See Waveform-2)

To cope with weak-signal noise, the noise detector is supported with the AGC (Automatic Gain Control) circuit. The noise component from the noise detector output is waveform-shaped by the mono-stable multivibrator (See Wave-

form-3). The output from the mono-stable multivibrator then couples to the gate circuit as a control-pulse array which is used to cut out only the pulsive noise component from the audio signal.

The memory provided at where holds the audiosignal level constant while the gate circuit is "closed".

The 19 kHz pilot-hold circuit serves to prevent stereo pilot-signal intermission.

The audio signal then sustains high-frequency-phase compensation to compensate for the phase shift due to the low-pass filter, then is coupled to the output terminal.

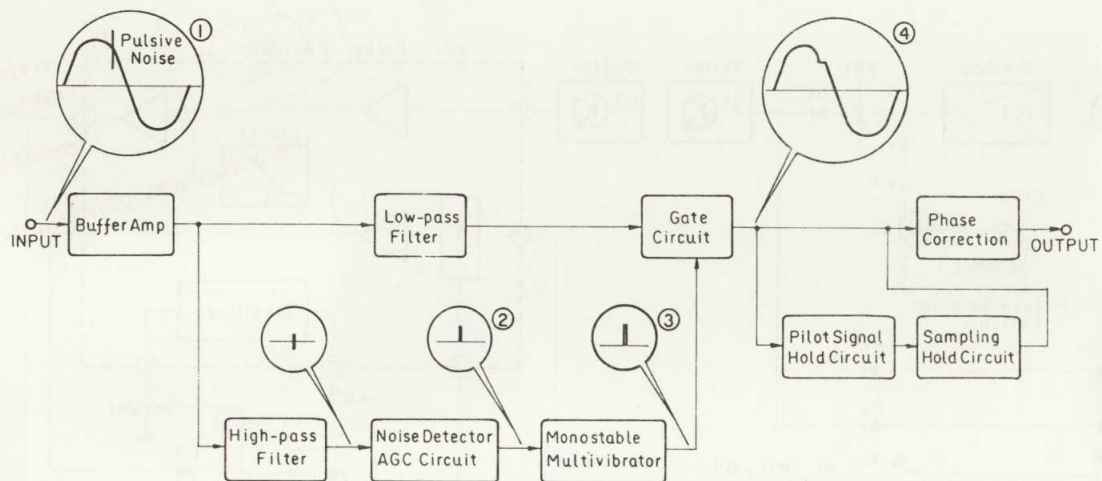

Fig. 12

## 3. ADJUSTMENT

KEX-20  
KEX-23

### 3.1 FM IF ADJUSTMENT

#### • Connection Diagram

\*Set the stereo unit for operation before making the adjustments.

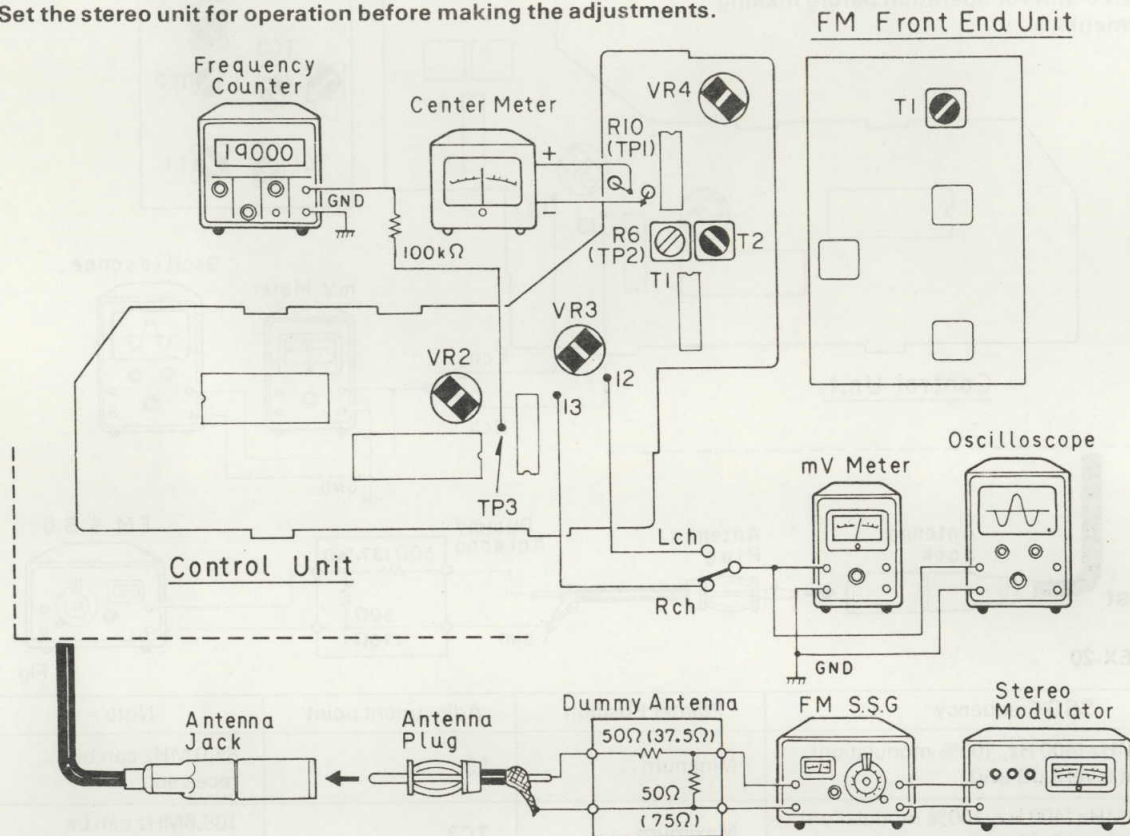

Fig. 13

#### • To Adjust

1. Add input signal of zero from SSG and adjust T2 so that the pointer of center meter (use one graduated for over  $200\mu\text{A}$ ) will come to the center.
2. Add output signal of 98 MHz 60 dB from SSG, multi-signal of modulated frequency 1 kHz of stereo modulator and tune to 98 MHz on the dial (the pointer of the center meter is at the center).
3. Adjust T1 (FM Front End Unit) so that separated signal will be minimal in its distortion factor.
4. Adjust FM IF by repeating the above procedure, steps 1, 2 and 3.

### 3.2 IF/MPX ADJUSTMENT

1. Shown in Fig. 13.
2. Select the band selector switch to stereo position.
3. Obtain non-modulation signal by setting SSG output at 60 dB ( $\mu\text{V}$ ) 98 MHz. Adjust VR2 so that the frequency counter indicates 19 kHz  $\pm 30$  Hz.
4. Obtain stereo modulation signal by setting SSG output at 60 dB ( $\mu\text{V}$ ). Adjust VR3 to secure maximum separation.

### 3.3 AUTO LEVEL ADJUSTMENT

1. Shown in Fig. 13.
2. Select the band selector switch to ARC position.
3. Set SSG at 98 MHz and tune using the tuning knob.
4. As SSG output gradually drops from 60 dB ( $\mu\text{V}$ ) to low level, and SSG output reduced to  $35 \pm 2$  dB ( $\mu\text{V}$ ), turn VR4 carefully and set it where stereo indicator is turned off.

ADJUSTMENT

3.4 FM TRACKING ADJUSTMENT

• Connection Diagram

\*Set the stereo unit for operation before making the adjustments.

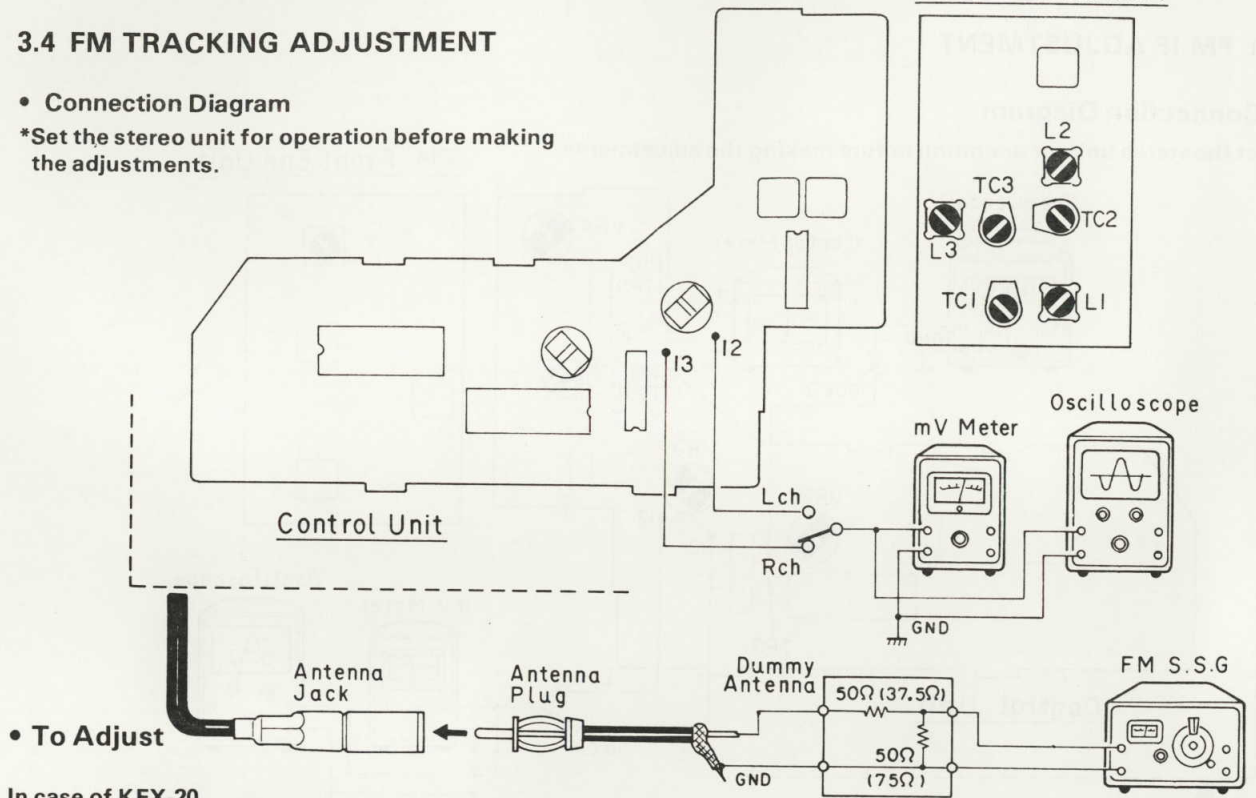

• To Adjust

In case of KEX-20

SSG Frequency	Pointer Position	Adjustment point	Note
1. 87.0 MHz (400 Hz, 100% modulation), output level 8 dB (μV)	Minimum	L3	87.0 MHz can be received
2. 108.6 MHz (400 Hz, 100% modulation), output level 8 dB (μV)	Maximum	TC3	108.6MHz can be received
3. Repeat items (1) and (2) alternately so that broadcast can be received at the frequency between 87.0 MHz and 108.6 MHz.			
4. 90 MHz (400 Hz, 100% modulation), output level 5 dB (μV)	Tuned position	L1, L2	Maximum output
5. 106 MHz (400 Hz, 100% modulation), output level 5 dB (μV)	Tuned position	TC1, TC2	Maximum output
6. Repeat items (4) and (5) alternately so that the mV meter indicates maximum output.			

In case of KEX-23

SSG Frequency	Pointer Position	Adjustment Point	Note
1. 87.0 MHz (400 Hz, 100% modulation), output level 8 dB (μV)	Minimum	L3	87.0 MHz can be received
2. 105.0 MHz (400 Hz, 100% modulation), output level 8 dB (μV)	Maximum	TC3	105.0 MHz can be received
3. Repeat items (1) and (2) alternately so that broadcast can be received at the frequency between 87.0 MHz and 105.0 MHz.			
4. 90 MHz (400 Hz, 100% modulation), output level 5 dB (μV)	Tuned position	L1, L2	Maximum output
5. 104 MHz (400 Hz, 100% modulation), output level 5 dB (μV)	Tuned position	TC1, TC2	Maximum output
6. Repeat items (4) and (5) alternately so that the mV meter indicates maximum output.			

Fig. 14

### 3.5 AM IF ADJUSTMENT (KEX-20)

• **Connection Diagram**

\*Set the stereo unit for operation before making the adjustments.

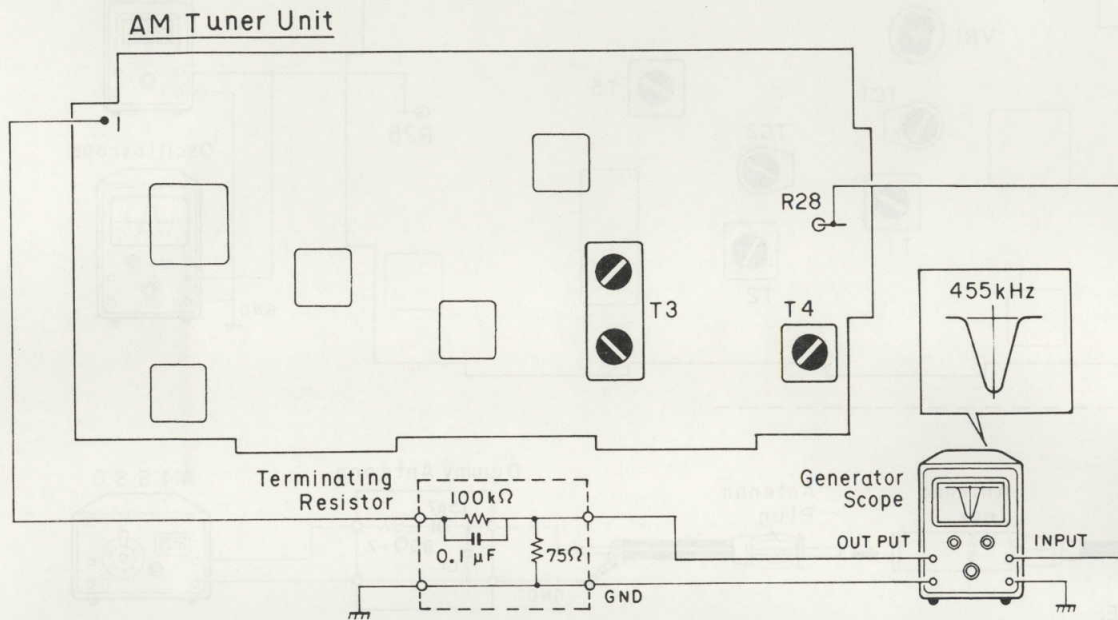

Fig. 15

• **To Adjust**

1. Set Generator Scope as follows:  
 Frequency centering on sweep ..... 455 kHz  
 Input level ..... 0.3Vp-p/cm  
 Output level ..... 3mV~10mV
2. Tune to a nearby, 1,600 kHz station.
3. Turn the cores of T3 and T4, and adjust so that U-curve will be at maximum amplitude and best symmetry.

ADJUSTMENT

3.6 AM TRACKING ADJUSTMENT (KEX-20)

• Connection Diagram

\*Set the stereo unit for operation before making the adjustments.

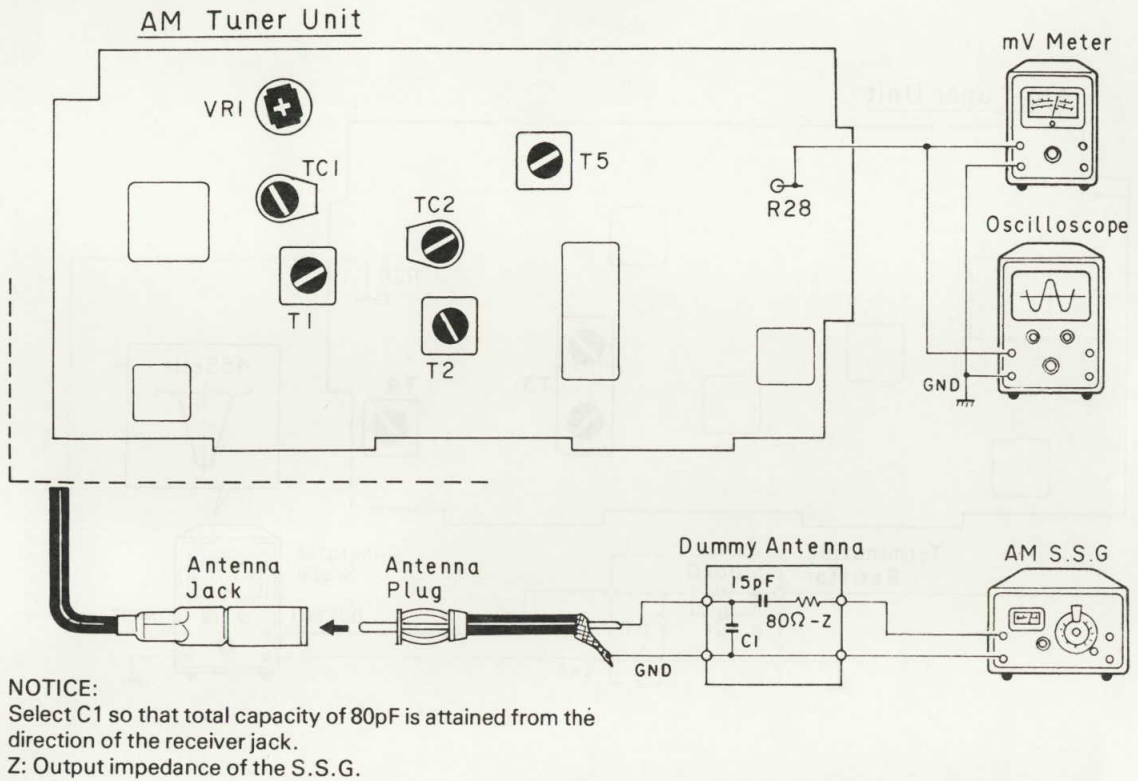

Fig. 16

• To Adjust

SSG Frequency	Pointer Position	Adjustment Point	Note
1. 1,630 kHz (400 Hz, 30% modulation), output level 30 dB (μV)	Maximum	T5	1,630 kHz can be received
2. 515 kHz (400 Hz, 30% modulation), output level 30 dB (μV)	Minimum	VR1	515 kHz can be received
3. 600 kHz (400 Hz, 30% modulation), output level 30 dB (μV)	Tune to 600 kHz	T1, T2	mV meter at maximum
4. 1,400 kHz (400 Hz, 30% modulation), output level 30 dB (μV)	Tune to 1,400 kHz	TC1, TC2	mV meter at maximum
5. Repeat items (3) and (4) alternately so that the mV meter indicates maximum output.			

### 3.7 MW/LW IF ADJUSTMENT (KEX-23)

• **Connection Diagram**

\*Set the stereo unit for operation before making the adjustments.

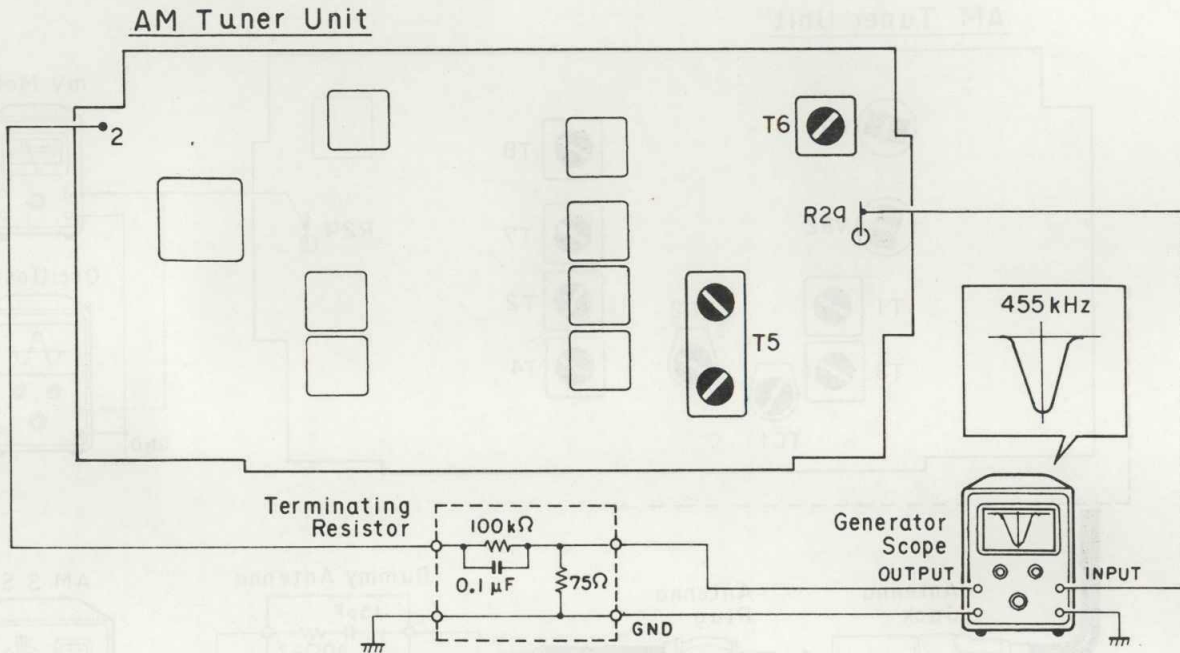

Fig. 17

• **To Adjust**

1. Set Generator Scope as follows:  
 Frequency centering on sweep . . . . . 455 kHz  
 Input level . . . . . 0.3Vp-p/cm  
 Output level . . . . . 3mV~10mV
2. Tune to a nearby 1,600 kHz station of MW.
3. Turn the cores of T5 and T6, and adjust so that U-curve will be at maximum amplitude and best symmetry.

Item	Adjustment	Pointer Position	250 kHz Frequency
1. 250 kHz (MW) 30% modulation output level 30 dB (1V)	T6	Maximum	1. 250 kHz (MW) 30% modulation output level 30 dB (1V)
2. 150 kHz (LW) 30% modulation output level 30 dB (1V)	V5	Minimum	2. 150 kHz (LW) 30% modulation output level 30 dB (1V)
3. 210 kHz (MW) 30% modulation output level 30 dB (1V)	T5, T6	Tune to 210 kHz	3. 210 kHz (MW) 30% modulation output level 30 dB (1V)

ADJUSTMENT

3.8 MW/LW TRACKING ADJUSTMENT (KEX-23)

• Connection Diagram

\*Set the stereo unit for operation before making the adjustments.

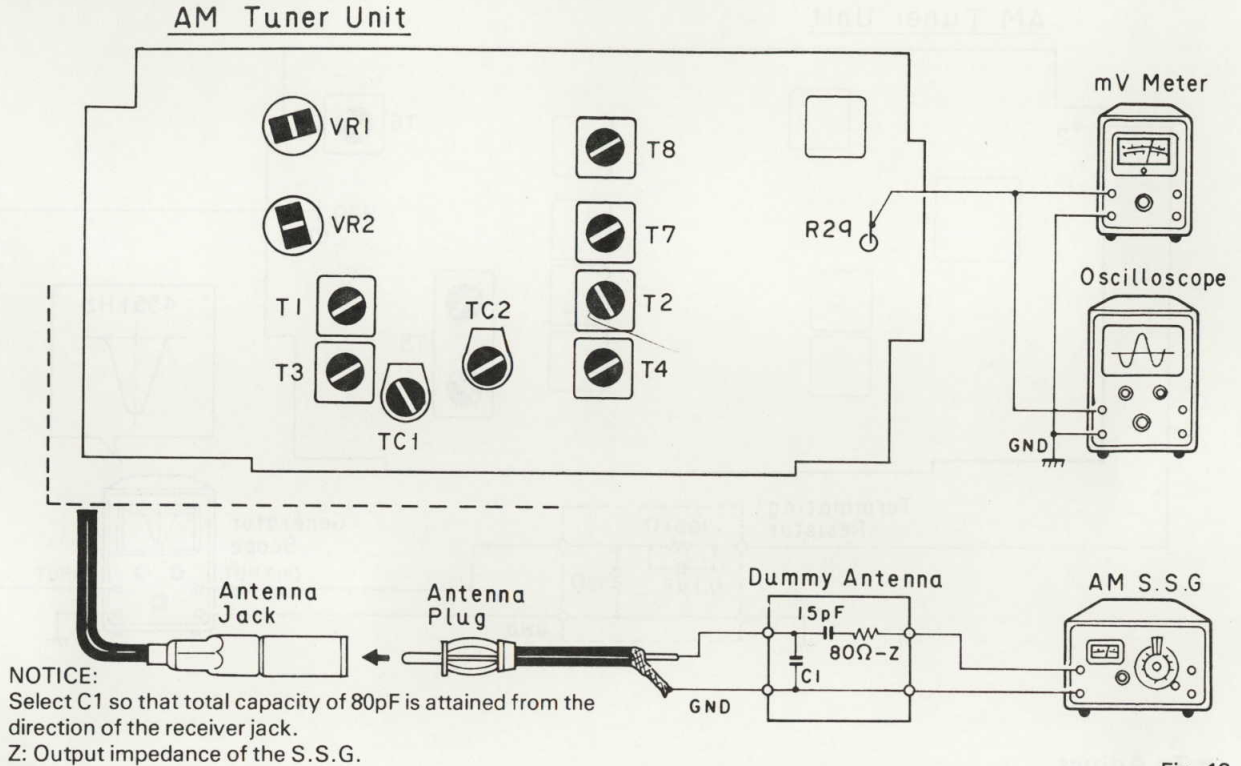

Fig. 18

• To Adjust

In case of MW (Select the band selector switch to MW)

SSG Frequency	Pointer Position	Adjustment	Note
1. 1,630 kHz (400 Hz, 30% modulation), output level 30 dB (μV)	Maximum	T7	1,630 kHz can be received
2. 515 kHz (400 Hz, 30% modulation), output level 30 dB (μV)	Minimum	VR1	515 kHz can be received
3. 600 kHz (400 Hz, 30% modulation), output level 30 dB (μV)	Tune to 600 kHz	T1, T4	mV meter maximum
4. 1,400 kHz (400 Hz, 30% modulation), output level 30 dB (μV)	Tune to 1,400 kHz	TC1, TC2	mV meter maximum
5. Repeat items (3) and (4) alternately so that the mV meter indicates maximum output.			

In case of LW (Select the band selector switch to LW)

SSG Frequency	Pointer Position	Adjustment	Note
1. 295 kHz (400 Hz, 30% modulation), output level 35 dB (μV)	Maximum	T8	295 kHz can be received
2. 145 kHz (400 Hz, 30% modulation), output level 35 dB (μV)	Minimum	VR2	145 kHz can be received
3. 215 kHz (400 Hz, 30% modulation), output level 35 dB (μV)	Tune to 215 kHz	T2, T3	mV meter maximum

### 3.9 DOLBY NR LAW ADJUSTMENT

#### • Connection Diagram

\*Set the stereo unit for operation before making the adjustments.

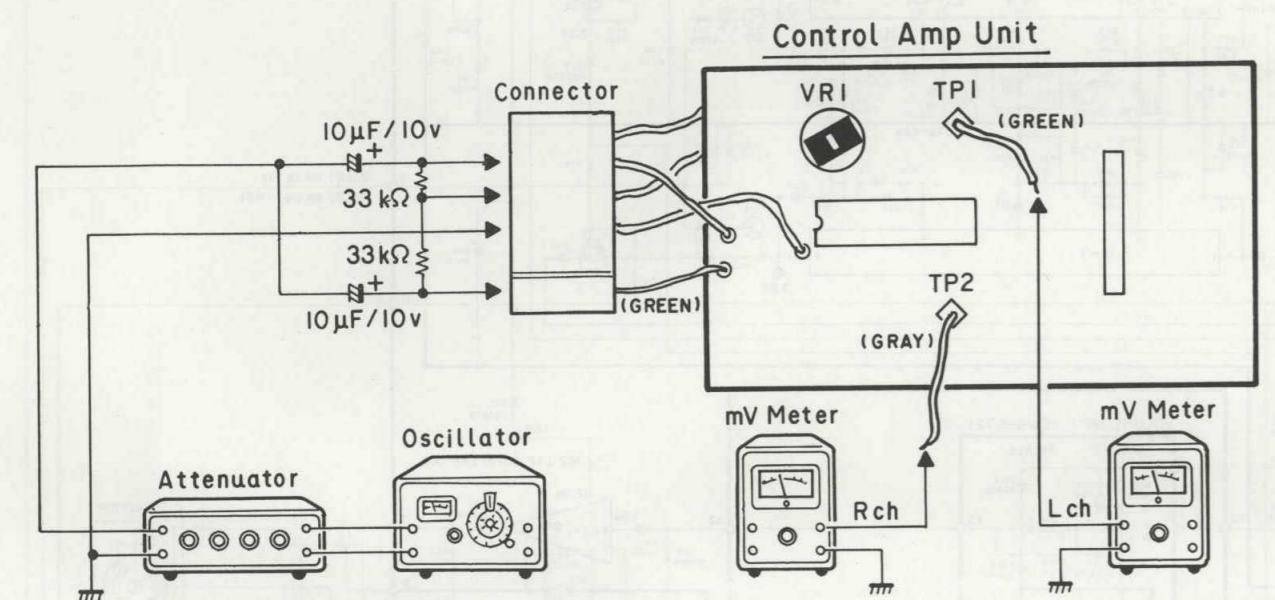

Fig. 19

#### • To Adjust

1. Load a cassette tape and set the unit to the playback mode.
2. Set the Dolby NR switch to OUT and apply a 5kHz input frequency signal from the oscillator. Adjust the attenuator so that mV meter pointer deflects to 58.7mV (-22.4dBs).
3. Now set the Dolby NR switch to IN and adjust VR1 so that mV meter pointer deflects to 23.4mV (-30.4dBs).

### 3.10 DOLBY NR LEVEL ADJUSTMENT

#### • Connection Diagram

\*Set the stereo unit for operation before making the adjustments.

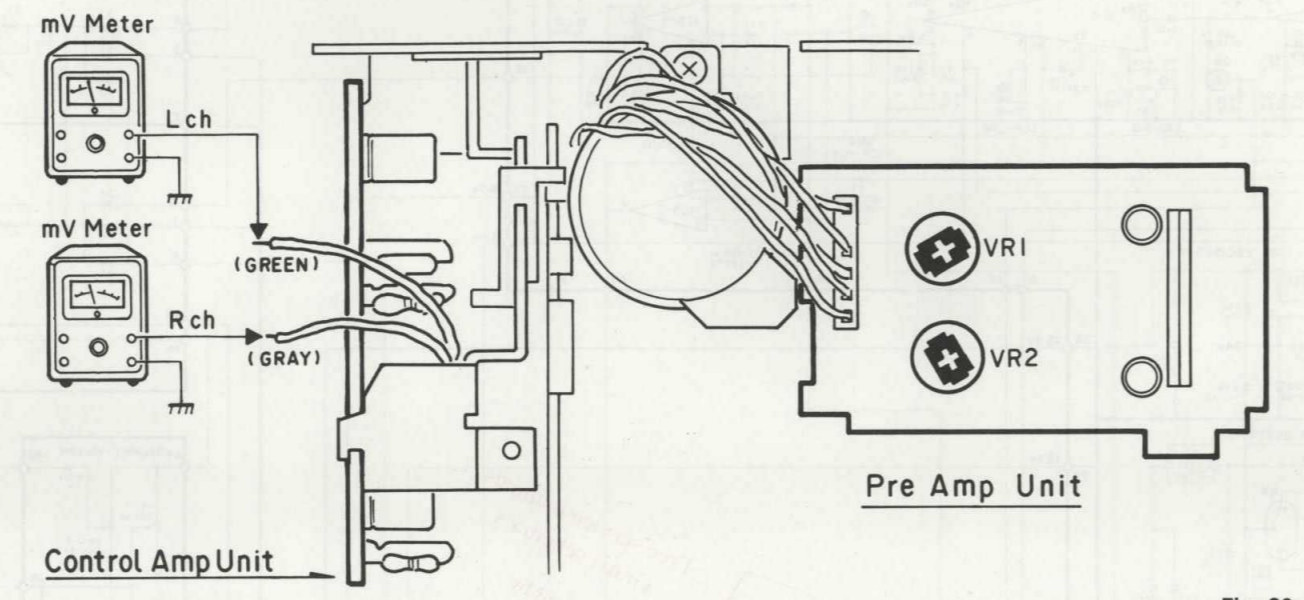
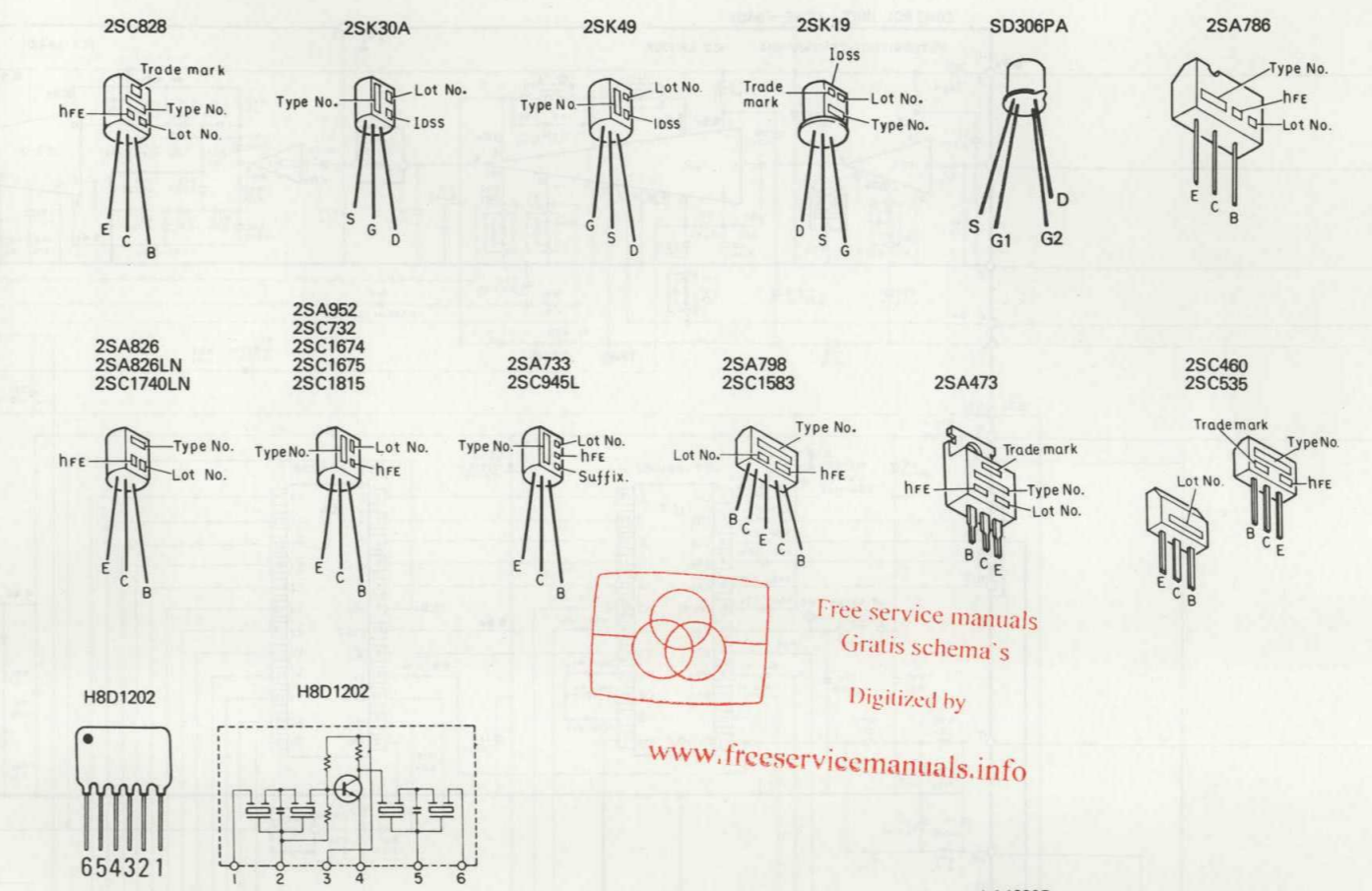

Fig. 20

#### • To Adjust

1. Play back the CT-150 (400Hz-200nwb/m) test tape and adjust VR1 (Lch) and VR2 (Rch) so that the mV meter pointer deflects to 775mV (0dBs).

#### • IC's and Transistors



Free service manuals  
Gratis schema's  
Digitized by  
www.freeservicemanuals.info

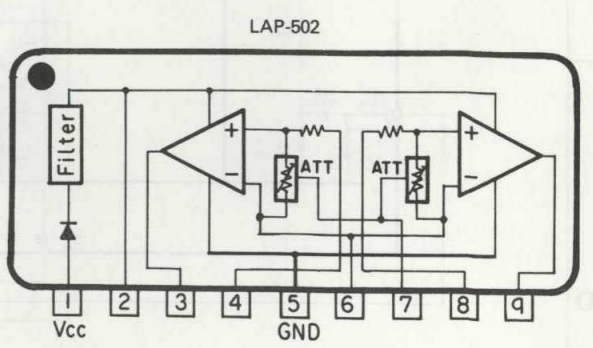
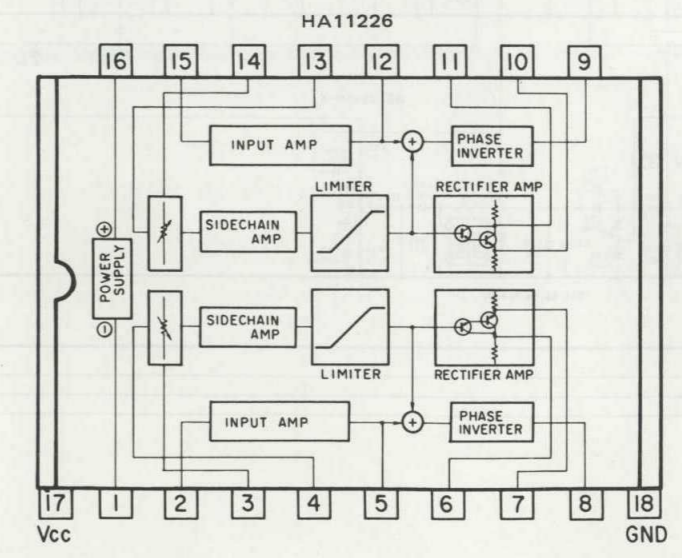
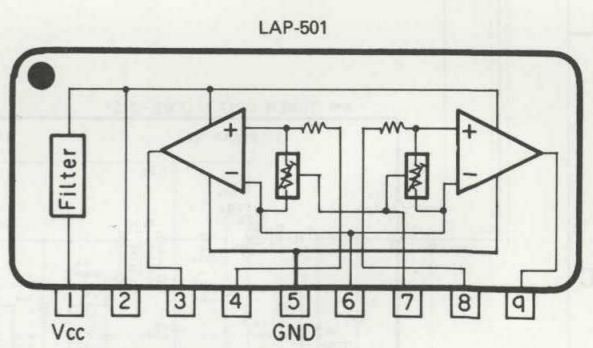
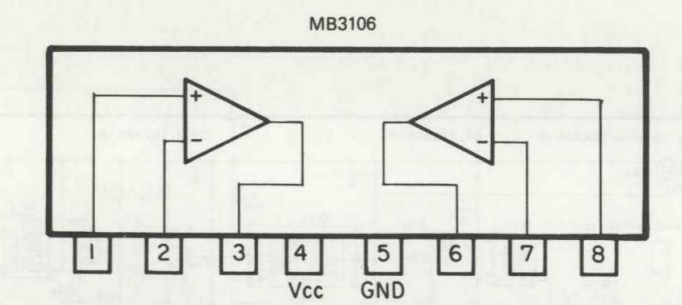
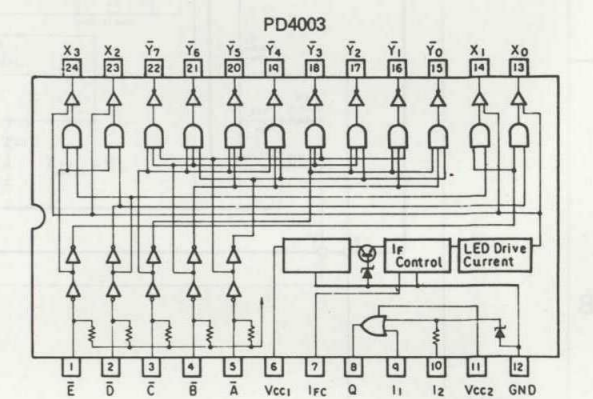
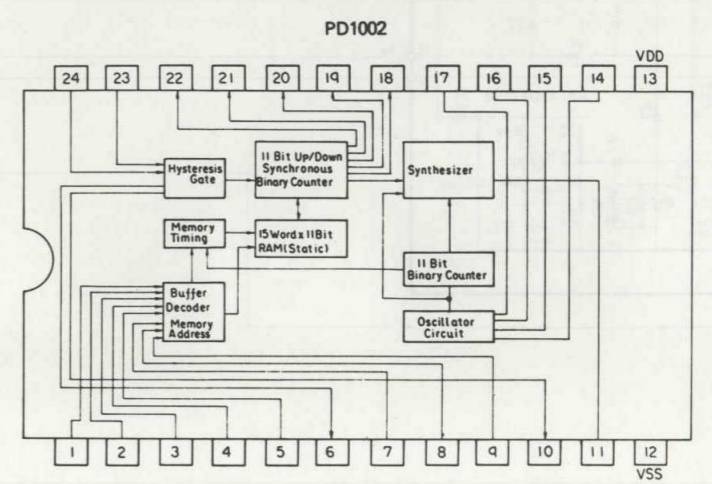
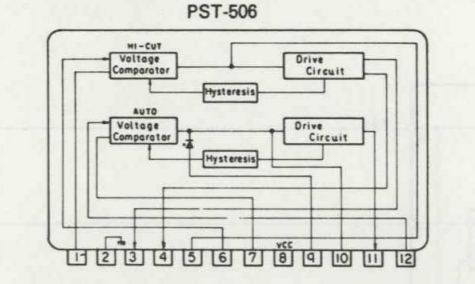



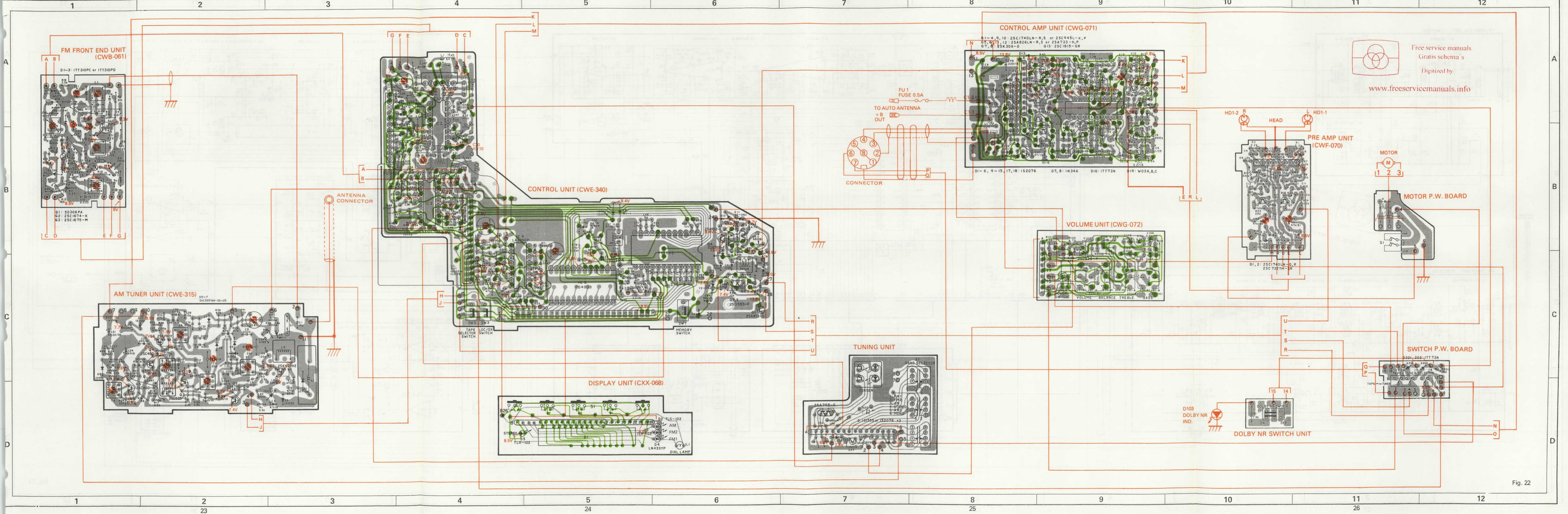

Free service manuals  
Gratis schema's  
Digitized by  
www.freeservicemanuals.info

Fig. 22

# 6. SCHEMATIC CIRCUIT DIAGRAM (KEX-23)

KEX-20  
KEX-23

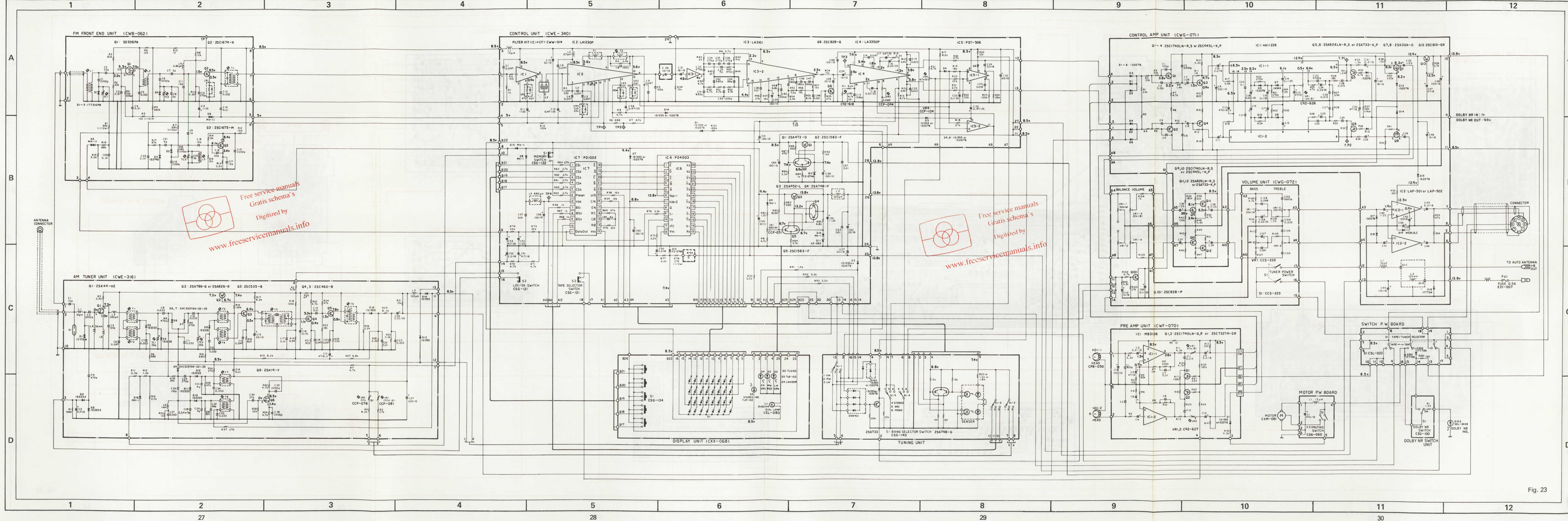

Free service manuals  
Gratis schema's  
Digitized by  
www.freeservicemanuals.info

Free service manuals  
Gratis schema's  
Digitized by  
www.freeservicemanuals.info

# 7. CONNECTION DIAGRAM (KEX-23)

KEX-20  
KEX-23

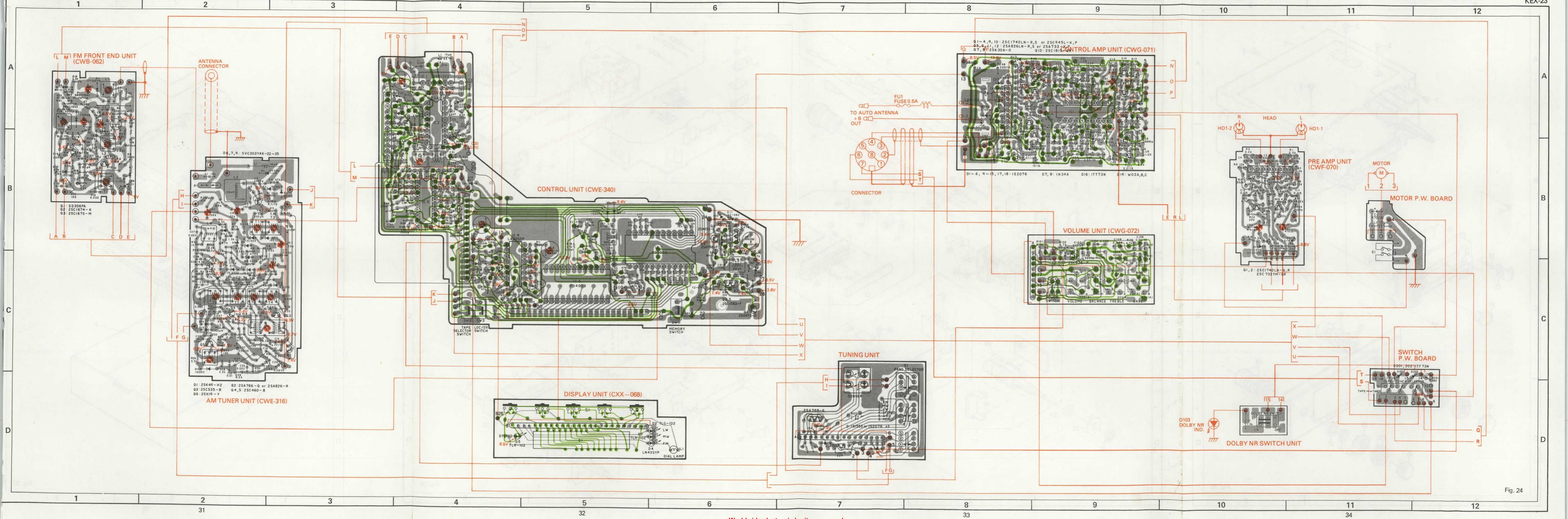
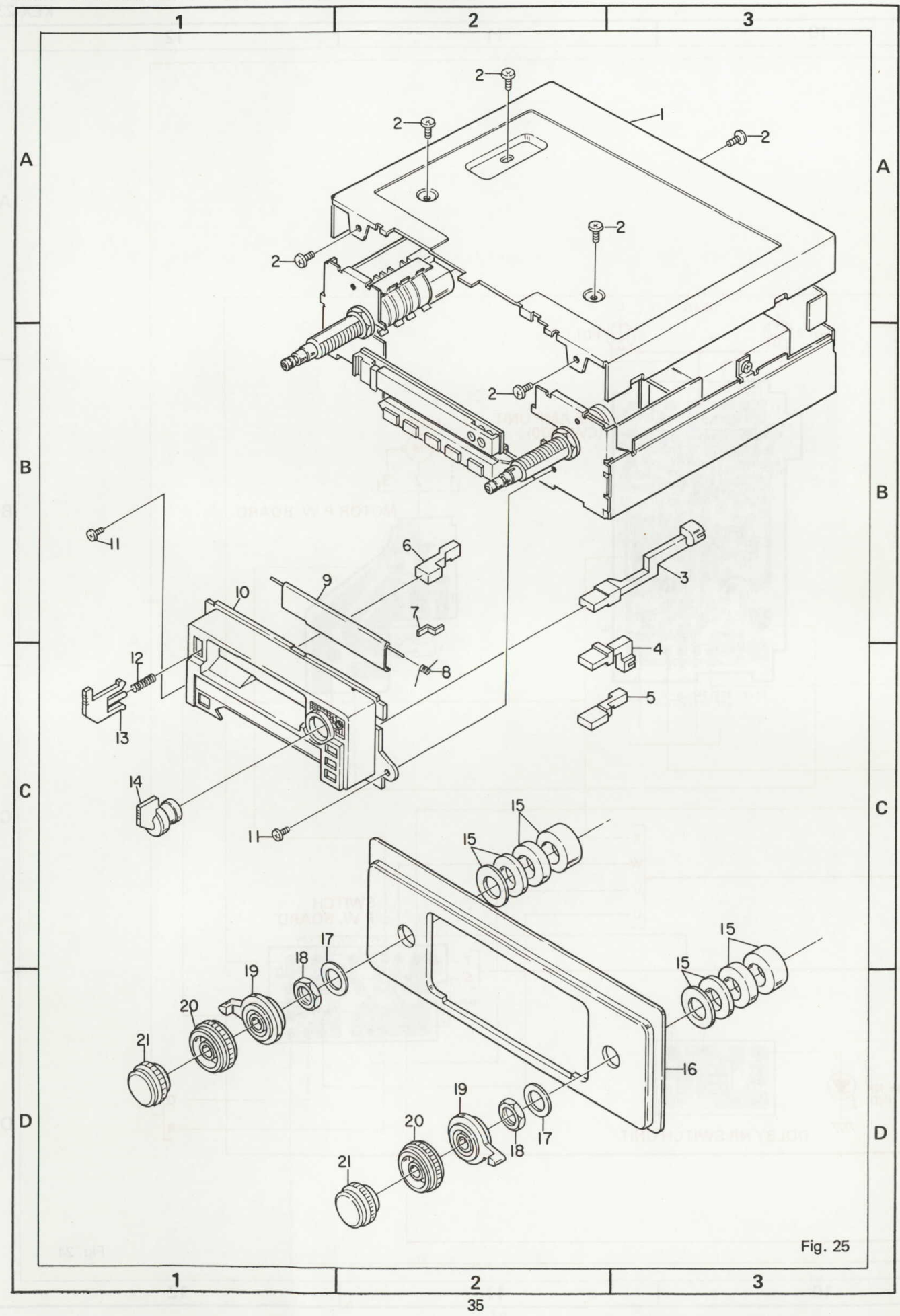
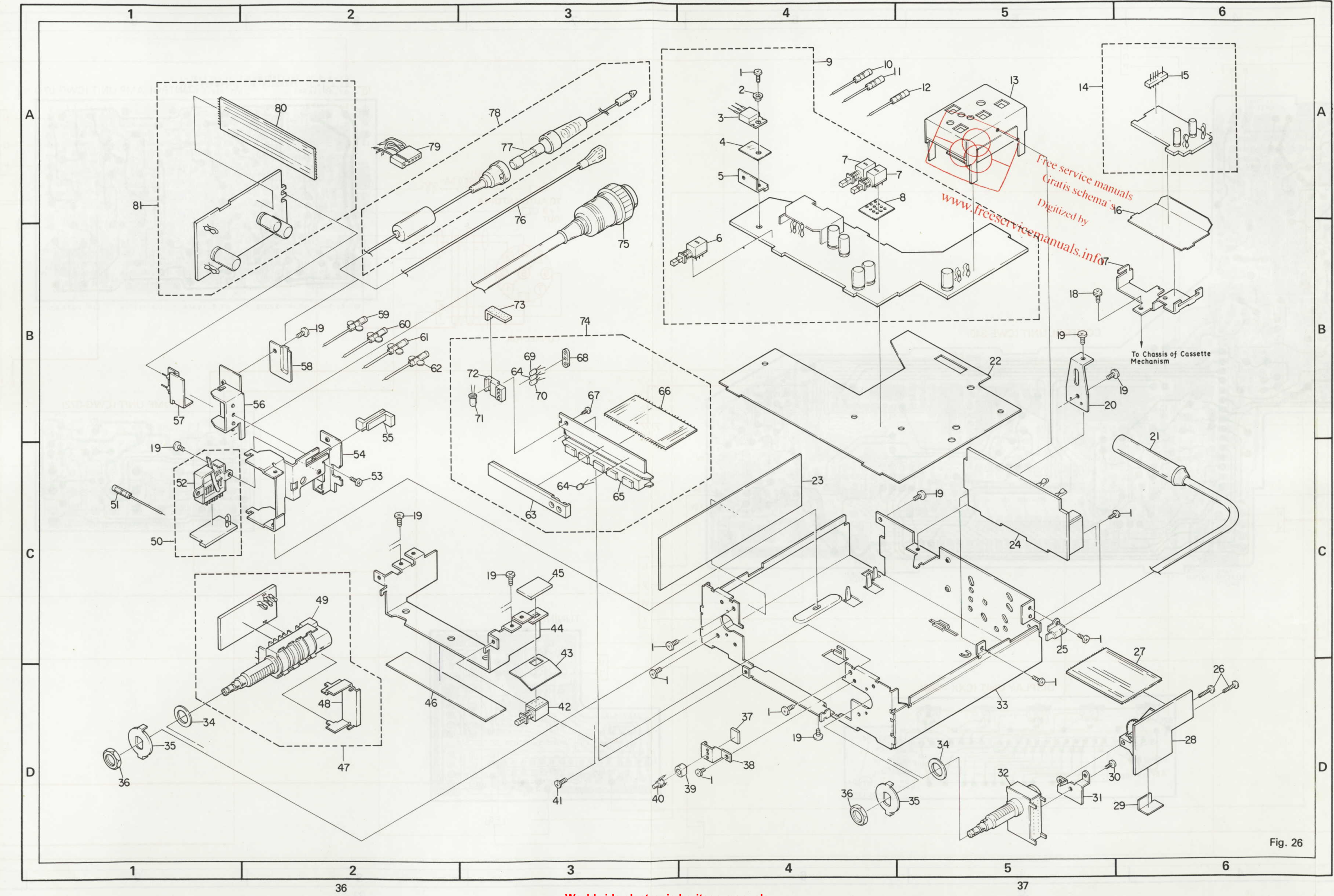

Fig. 24

### 8. CABINET EXPLODED VIEW



### 9. CHASSIS EXPLODED VIEW



KEX-20  
KEX-23

### 10. PACKING METHOD

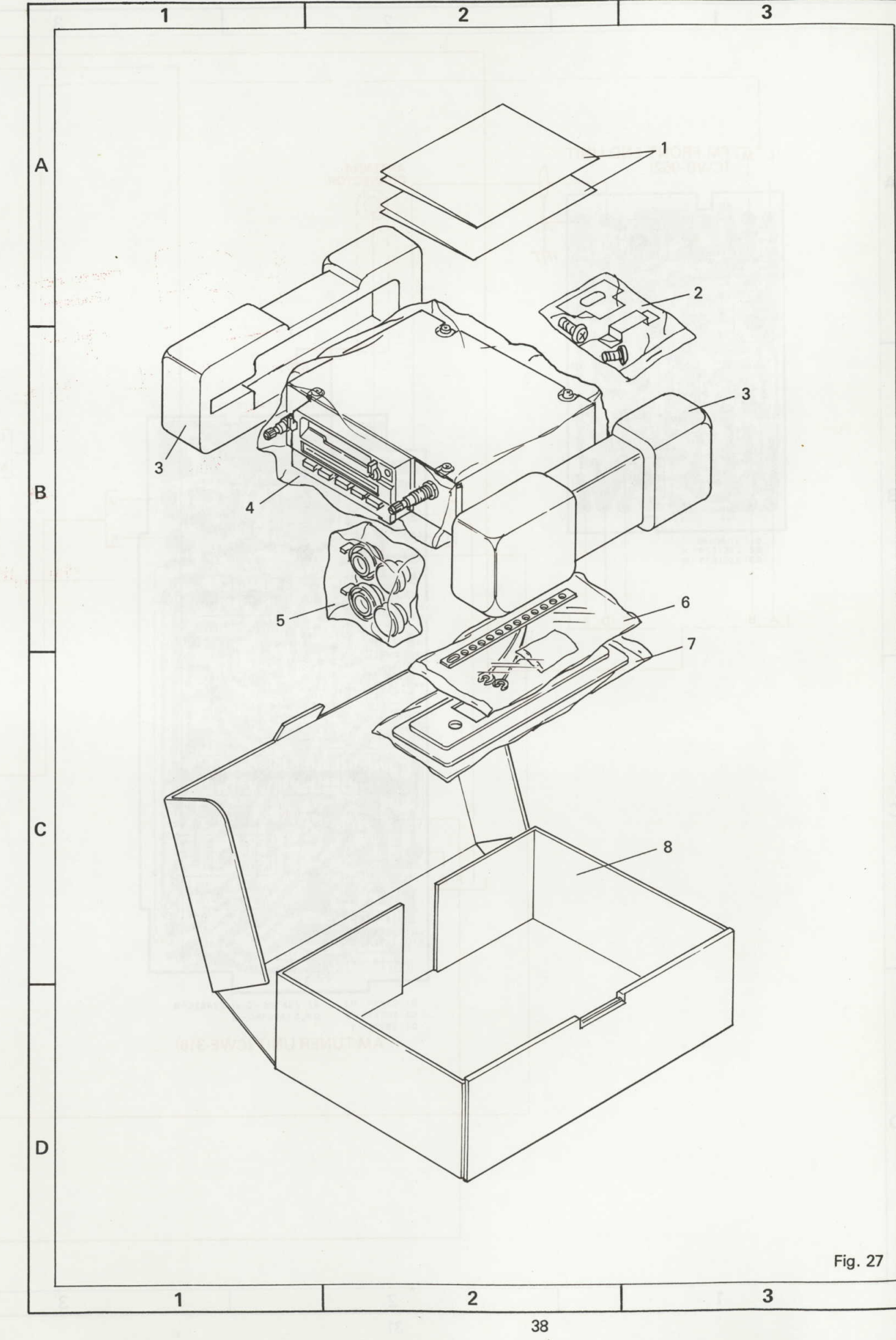

# 11. PARTS LIST KEX-20 KEX-23

**NOTE:**

When ordering resistors, first convert resistance values into code form as shown in the following examples.

Ex. 1 When there are 2 effective digits (any digit apart from 0), such as 560 ohm and 47k ohm (tolerance is shown by J = 5%, and K = 10%).

560Ω	56 × 10 <sup>1</sup>	561	.....	RD1/4PS	<span style="border: 1px solid black; padding: 0 2px;">5</span> <span style="border: 1px solid black; padding: 0 2px;">6</span> <span style="border: 1px solid black; padding: 0 2px;">1</span>	J
47kΩ	47 × 10 <sup>3</sup>	473	.....	RD1/4PS	<span style="border: 1px solid black; padding: 0 2px;">4</span> <span style="border: 1px solid black; padding: 0 2px;">7</span> <span style="border: 1px solid black; padding: 0 2px;">3</span>	J
0.5Ω	OR5	.....	.....	RN2H	<span style="border: 1px solid black; padding: 0 2px;">0</span> <span style="border: 1px solid black; padding: 0 2px;">R</span> <span style="border: 1px solid black; padding: 0 2px;">5</span>	K
1Ω	010	.....	.....	RS1P	<span style="border: 1px solid black; padding: 0 2px;">0</span> <span style="border: 1px solid black; padding: 0 2px;">1</span> <span style="border: 1px solid black; padding: 0 2px;">0</span>	K

Ex. 2 When there are 3 effective digits (such as in high precision metal film resistors).  
5.62 kΩ 562 × 10<sup>1</sup> ..... RN1/4SR 5621 F

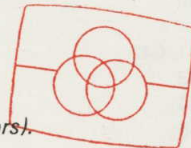

Free service manuals  
Gratis schema's  
Digitized by  
[www.freeservicemanuals.info](http://www.freeservicemanuals.info)

- Parts whose parts numbers are omitted are subject to being not supplied.

## Control Unit (CWE-340)

### MISCELLANEOUS

Part No.	Symbol & Description
CWW-014	IC1(IC & Ceramic Filter)
LA1230P	IC2
LA2101	IC3
LA3350P	IC4
PST-506	IC5
PD4003	IC6
PD1002	IC7
2SA473-O	Q1
2SC1583	Q2, Q5
2SA952	Q3
2SA798	Q4
2SC828	Q6
1S1555 or 1S2076	D1, D2, D4-D7, D14
VACANT	D3
MV-1	D8-D10, D15
XZ-062	D11
YZ-074A	D12, D13
CTF-016	L1 Ferri-Inductor, 15μH
CTF-039	L2 Ferri-Inductor, 2.7μH
CTC-106	L3 Coil, 330μH
CTC-094	L4 Coil, 680μH
CTC-108	T1 Coil
CTC-109	T2 Coil
CWW-026	CR1 470Ω/0.01μF
CWW-031	CR2 10kΩ/0.01μF
CWW-047	CR3 100kΩ/0.01μF
CWW-032	CR4 22kΩ/0.01μF
CCP-051	VR1 Volume, 680Ω (B)
C92-618	VR2 Semi-fixed, 4.7kΩ (B)
CCP-094	VR3 Semi-fixed, 2.2kΩ (B)
CCP-104	VR4 Volume, 4.7kΩ (B)
CSG-122	S1 Switch
CSG-121	S2, S3 Switch

### RESISTORS

Part No.	Symbol & Description
RD1/8VS	□□□J R1-R4, R7, R8, R11-R16
RD1/2PS	□□□J R18-R22, R24, R25, R30-R35
RD1/4PS	□□□J R39-R70, R75-R77, R82-R93
RD1/8PS	□□□J R6, R10, R17
RD1/2PS	□□□J R78
CCN-060	R23 22kΩ
CCN-052	R71, R72, R81 4.7kΩ
CCN-036	R73, R74 22kΩ
CCN-034	R80 1.2kΩ
VACANT	R5, R9, R26-R29, R36-R38
	R79

### CAPACITORS

Part No.	Symbol & Description
CKDYF473Z25	C1-C4, C6, C9
CCDSL101K50	C5
VACANT	C7, C12
CCDRH101J50	C8
CSZAR47M35	C10, C17, C22, C54, C58
CSZA010M25	C11, C53, C61
CEA330M10L	C13
CQMA473K50	C14
CQSA152J50	C15
CSZAR22M35	C16
CSZAR33M35	C18
CQMA223J50	C19, C20
CEA101M10L	C21, C32, C39, C56, C60, C64
	C66, C68
CSZA0R1M35	C23
CQMA183K50	C24, C25
VACANT	C26
CEA330M16L	C27
CSZA100M10	C28, C29
VACANT	C30

## PARTS LIST

Part No.	Symbol & Description
CEA100M16L	C31
CKDSA271J50	C33-C36
CCDSL050D50	C37
CQMA103K50	C38
CQMA152J50	C40
CKDSA681J50	C41, C42
CQMA122K50	C43
CKDSA680J50	C44
CQMA682J50	C45
CKDSA561J50	C46, C47
CKDSA102J50	C48
CCDCH080D50	C49
CSZA2R2M16	C50, C52
CSZA4R7M16	C51
VACANT	C55
CKDYF103Z25	C57, C63, C67
CSZA100M16	C59
CEA220M16L	C62
VACANT	C65

**AM Tuner Unit (CWE-315) (KEX-20)****MISCELLANEOUS**

Part No.	Symbol & Description	
2SK49-H2	Q1	
2SA786-Q or 2SA826-R	Q2	
2SC535-B	Q3	
2SC460-B	Q4, Q5	
2SK19-Y	Q6	
ITT73N	D1	
1S2222	D2, D3	
1S1555	D4, D9, D10	
SVC303YAK	*D5 ~ D7	
MV-1	D8	
CTB-068	L1	Coil, 10 $\mu$ H
VACANT	L2	
CTH-049 or CTH-057	L3	Coil Coil, 18 $\mu$ H
CTB-070	L4	Coil, 220 $\mu$ H
T24-030	L5	Ferri-Inductor, 100 $\mu$ H
CTB-081	L6	Coil, 2.2 $\mu$ H
CTB-078	T1	Coil
CTB-073	T2	Coil
CTE-037	T3	IF Transformer
CTB-075	T4	Coil
CTB-080	T5	Coil
C43-607	TC1, TC2	Ceramic Trimmer
CCP-063	VR1	Volume, 68k $\Omega$ (B)
CCX-006	G1	Lightning Piece

**RESISTORS**

Part No.	Symbol & Description
RD1/8VS□□□J	R1-R3, R9-R27, R30 R33-R40
RD1/8PS□□□J	R28
CCN-054	R41 27k $\Omega$
VACANT	R4-R8, R29, R31, R32

**CAPACITORS**

Part No.	Symbol & Description
CCDSL150K500L	C1
CKDYB471K50	C2, C5, C26
CSZA4R7M10	C3
CKDYB121K50	C4
CKDBC473M25	C6, C13, C16, C18
CQMA223J50	C7-C11, C33, C34
CKDYD103M50	C12
CEA330P10	C14
CKDYF103Z25	C15, C17
CQMA103M50	C19
CQMA273K50	C20
CSZAR22M35	C21
VACANT	C22
CCH-028	C23 220 $\mu$ F/10V
CEA470P10	C24
CSZA100M10	C25
CKDYB222K50	C27
CCDVK330J50	C28
CCDWK100F50	C29
CCDCH050D50 or	*C30
CCDCH060D50 or	
CCDCH070F50 or	
CCDCH080F50	
CCDPH271J50L	C31
CCDPH151J50L	C32

**Caution:**

Diodes \*D5-D7 and Capacitor \*C30 used mutually in the following assembly.

D5-D7	C30
SVC303YAK-25	CCDCH050D50
SVC303YAK-24	CCDCH060D50
SVC303YAK-23	CCDCH070F50
SVC303YAK-22	CCDCH080F50

## PARTS LIST

KEX-20  
KEX-23

## AM Tuner Unit (CWE-316) (KEX-23)

## MISCELLANEOUS

Part No.	Symbol & Description
2SK49-H2	Q1
2SA786-Q or 2SA826-R	Q2
2SC535-B	Q3
2SC460-B	Q4, Q5
2SK19-Y	Q6
ITT73N	D1
1S2222	D2, D3, D5, D8, D11-D13
1S1555	D4, D10, D14, D15
SVC303YAK	*D6, D7, D9
MV-1	D16
CTB-068	L1 Coil, 10 $\mu$ H
CTB-069	L2 Coil, 56mH
CTB-070	L3 Coil, 220 $\mu$ H
CTB-071	L4 Coil, 1mH
T24-030	L5 Ferri-Inductor, 100 $\mu$ H
CTB-081	L6 Coil
CTB-072	T1 Coil
CTB-073	T2 Coil
CTB-074	T3, T4 Coil
CTE-037	T5 IF Transformer
CTB-075	T6 Coil
CTB-080	T7 Coil
CTB-077	T8 Coil
CCG-030	TC1, TC2 Ceramic Trimmer, 20pF
CCP-081	VR1 Volume, 100k $\Omega$ (B)
CCP-078	VR2 Volume, 22k $\Omega$ (B)
CCX-006	G1 Lightning Piece

## RESISTORS

Part No.	Symbol & Description
RD1/8VS□□□J	R1, R2, R5-R28, R30-R40
CCN-054	R3 27k $\Omega$
CCN-055	R4 8.2k $\Omega$
RD1/8PS□□□J	R29

## CAPACITORS

Part No.	Symbol & Description
CCDSL150K500L	C1
CKDYB222K50	C2, C35, C36
CSZA4R7M10	C3
CKDYB471K50	C4
CKDYB121K50	C5
CKDBC473M25	C6, C13, C18, C20
CQMA333K50	C7, C8, C10-C12, C27, C33
	C34
VACANT	C9
CKDYD103M50	C14
CSZA220M10	C15
CSZA100M10	C16
CKDYF103Z25	C17, C19
CEA470P6.3	C21
CQMA103M50	C22
CQMA223K50	C23
CSZAR22M35	C24
CCDPH271J50L	C25
CCDPH151J50L	C26
CCDCH020C50 or	*C28
CCDCH030C50 or	
CCDCH040C50 or	
CCDCH050C50	
CCDPH090D50	C29
CCDXK270J50	C30
CCDXK090D50	C31
CCDPH680J50	C32
CCH-028	C37 220 $\mu$ F/10V

## Caution:

Diodes \*D6, D7, D9 and capacitor \*C28 used mutually in the following assembly.

D6, D7, D9	C28
SVC303YAK-25	CCDCH020C50
SVC303YAK-24	CCDCH030C50
SVC303YAK-23	CCDCH040C50
SVC303YAK-22	CCDCH050C50

## PARTS LIST

FM Front End Unit (CWB-061) (KEX-20)  
(CWB-062) (KEX-23)

## MISCELLANEOUS

Part No.	Symbol & Description
SD306PA	Q1
2SC1674	Q2
2SC1675-M	Q3
ITT310PC, PD	D1-D3 (KEX-20)
ITT310PB	D1-D3 (KEX-23)
1S2790	D4
MV-11	D5, D6
CTC-107	L1 Coil
CTC-092	L2 Coil
CTC-093	L3 Coil
CTF-015	L4 Ferri-Inductor, 0.82 $\mu$ H
CTC-043	T1 IF Transformer
CCG-038	TC1-TC3 Ceramic Trimmer
CTX-022	Beaded Core
CCX-001	CR1 1k $\Omega$ /2200pF

## RESISTORS

Part No.	Symbol & Description
CCN-041	R1, R7, R16 68k $\Omega$ /1/10W
RD1/8VS□□□J	R2, R6, R8, R11-R15
RD1/8PS□□□J	R3, R10
CCN-040	R4 33k $\Omega$ /1/10W
CCN-007	R5 10k $\Omega$ /1/10W
CCN-059	R9 560k $\Omega$
CCN-058	R17 47k $\Omega$
CCN-037	R18 82k $\Omega$ (KEX-20)
CCN-053	R18 68k $\Omega$ (KEX-23)
CCN-057	R19 3.3k $\Omega$

## CAPACITORS

Part No.	Symbol & Description
CKDYA222K50	C1, C6, C15, C19
CCDSL330J50	C2
CKDYF103Z25	C3, C4, C14, C22, C23
CKDYF223Z25	C5, C13
CCDCH030D50	C7
CCDSH030D50	C8
CGB010K500	C9
CKDYB271K50	C10
CCDCH100F50	C11
CSZA010M25	C12
CCDSH330J50	C16
CCDTH100J50	C17 (KEX-20)
CCDTH120J50	C17 (KEX-23)
CCDRH100F50	C18
CCDTH030D50	C20
CCDTH050D50	C21

## Control Amp Unit (CWG-071)

## MISCELLANEOUS

## NOTICE:

With Q1 through Q4, Q9 and Q10, Q5 and Q6, and with Q11 and Q12, use identical units for both channels and units of the same rank.

When LAP-502 is used with IC2, delete D15 and short circuit the gap.

Part No.	Symbol & Description
HA11226	IC1
LAP-501 or LAP-502	IC2
2SC1740LN-R, S or 2SC945L-P, K	Q1-Q4, Q9, Q10
2SA826LN-R, S or 2SA733-P, K	Q5, Q6, Q11, Q12
2SK30A	Q7, Q8
2SC1815-GR	Q13
1S2076	D1-D6, D9-D15, D17, D18
1N34A	D7, D8
ITT73N	D16
W03A, B, C	D19
CTH-035	L1 Coil, 10 $\mu$ H
T24-030	L2 Ferri-Inductor, 100mH
C92-626	VR1 Semi-fixed, 10k $\Omega$ (B)

## RESISTORS

Part No.	Symbol & Description
RD1/8VS□□□J	R1-R36, R38-R54, R56
RD1/4VS□□□J	R37
VACANT	R55

## CAPACITORS

Part No.	Symbol & Description
CKDYB101K50	C1, C2
CQMA102J50	C3, C4
CQMA682J50	C5, C6
CSZA010M25	C7, C8, C33, C34, C36, C37 C40, C41, C50
CEA221M10L	C9
CSZA2R2M16	C10, C11, C31, C32, C43, C44
CEA471M16L	C12
CEA470M10L	C13
CSZA0R1M35	C14-C17
CSZAR33M35	C18, C19, C24 C25
CQMA104J50	C20, C21
CQMA472J50	C22, C23
CQMA153J50	C26-C29
CEA470M16L	C30, C47
VACANT	C35
CSZA4R7M25	C38, C39
CEA101M16L	C42, C45
CEA100M16L	C46, C49
CEA221M16L	C48

# PARTS LIST KEX-20 KEX-23

## Volume Unit (CWG-072)

### MISCELLANEOUS

Part No.	Symbol & Description
2SC828	Q101
CCS-223	VR1 Volume/ Switch 20k $\Omega$ (A) $\times$ 2, 20k $\Omega$ (B) 50k $\Omega$ (W)
CCS-223	S1 Volume/ Switch

### RESISTORS

Part No.	Symbol & Description
RD1/8VS□□□J	R101-R103, R106, R107, R110, R111
CCN-031	R104, R105 1k $\Omega$
CCN-065	R108, R109 1.5k $\Omega$

### CAPACITORS

Part No.	Symbol & Description
CSZAOR1M35	C101
CQMA562J50	C102, C103
CQMA333J50	C104, C105
CSZAR33M35	C106, C107
CQMA683J50	C108, C109
CSZA100M16	C110

## Pre Amp Unit (CWF-070)

### MISCELLANEOUS

**NOTICE:**  
As for the Q1 and Q2, use the same ones and the same rank for both channels.

Part No.	Symbol & Description
MB3106	IC1
2SC1740LN-Q, R or 2SC732 TM-GR	Q1, Q2
1S1555 or 1S2076	D1
C92-627	VR1, VR2 Volume, 47k $\Omega$ (B)

### RESISTORS

Part No.	Symbol & Description
RD1/8VS□□□J	R1-R24

## CAPACITORS

Part No.	Symbol & Description
CKDYB821K50L	C1, C2
CSZA2R2M16	C3, C4, C9, C10
CEA470M10L	C5, C6
CQMA103J50	C7, C8
CQMA153J50	C11, C12
CEA101M10	C13

## Display Unit (CXX-068)

Part No.	Symbol & Description
	D1 LED Array
TLG-102	D2
TLR-102	D3, D5
LN43SYP	D4
CEL-080	IL1 Lamp, 8V 60mA
CSG-134	S1 Switch

## Tuning Unit

Part No.	Symbol & Description
1S1555 or 1S2076	D102 (KEX-23)
CSG-140	S1 Switch
CWM-040	Generator Unit

## Switch P.W. Board

Part No.	Symbol & Description
ITT73N	D201, D202
CCN-067	R201 180 $\Omega$
CSL-023	S1 Switch

## Dolby NR Switch Unit

Part No.	Symbol & Description
CCN-065	R1 1.5k $\Omega$
CSG-100	S1 Switch

## Motor P.W. Board

Part No.	Symbol & Description
CEA471M16L	C1
T63-618	L1 Coil

## PARTS LIST

## Miscellaneous Parts List

Part No.	Symbol & Description
1S1555 or 1S2076	D101 (KEX-20)
VACANT	D102
SEL-303E	D103
CCN-056	R94      0Ω
CCL-088	C1      Feed through Capacitor
CSZA100M10	C30
CSN-060	S1      Switch
E21-007	FU1      Fuse, 0.5A
CPB-050	HD1      Head
CXM-061	M      Motor

## Cabinet

Key No.	Part No.	Description
1.	CNB-493	Case
2.	B10-861-A	BM3×4
3.	CAC-282	Button
4.	CAC-283	Button
5.	CAC-285	Button
6.	CAC-270	Button
7.	CNE-230	Holder
8.	CBH-398	Spring
9.	CAT-080	Door
10.	CXX-065	Grille Unit (KEX-20)
	CXX-066	Grille Unit (KEX-23)
11.	B10-810-A	BM2.6×5
12.	CBH-399	Spring
13.	CAC-269	Button
14.	CAA-268	Knob
15.	CNV-769	Washer
16.		Panel
17.	CND-646	FW10ø×1t
18.	CBN-016	N10ø×3t
19.	CAA-298	Knob
20.	CAA-297	Knob
21.	CAA-313	Knob

## Chassis

Key No.	Part No.	Description
1.	B10-810-A	BM2.6×5
2.	B21-679	Insulating Bush
3.	2SA473-O	Transistor
4.	CNM-352	Insulating Plate
5.		Heat Sink
6.	CSG-122	Switch
7.	CSG-121	Switch
8.		Insulator
9.	CWE-340	Control Unit
10.		Connector
11.		Connector
12.		Connector
13.	CWB-061	FM Front End Unit (KEX-20)
	CWB-062	FM Front End Unit (KEX-23)
14.	CWF-070	Pre Amp Unit
15.	CKS-060	Plug
16.		Insulator
17.		Bracket
18.	B06-111-A	PSA2.6×6
19.	B10-861-A	BM3×4
20.		Holder
21.	CDH-036	Antenna Cable
22.		Insulator
23.	CNM-540	Insulator
24.	CWE-315	AM Tuner Unit (KEX-20)
	CWE-316	AM Tuner Unit (KEX-23)
25.	CND-801	Clamper
26.	B10-216-A	PM2.6×16
27.	CDE-527	Connector
28.	CWM-040	Generator Unit
29.		Insulator
30.	B10-209-A	PM2.6×4
31.		Holder
32.	CSG-140	Switch
33.		Chassis
34.	CND-646	FW10ø×1t
35.	CNE-416	Guide
36.	CBN-016	N10ø×3t
37.	CNP-753	P.W. Board
38.		Holder
39.	CNW-040	Spacer
40.	SEL-303E	LED
41.	B10-612-A	CM2.6×8
42.	CSG-100	Switch
43.		Cover
44.		Holder
45.		P.W. Board
46.		Insulator
47.	CWG-072	Volume Unit
48.		Guide

PARTS LIST KEX-20  
KEX-23

Key No.	Part No.	Description	Packing Method		
			Key No.	Part No.	Description
49.	CCS-223	Volume/ Switch			
50.		Switch P.W. Board			
51.		Connector	1.	CRD-070	Owner's Manual (KEX-20)
52.	CSL-023	Switch		CRD-071	Owner's Manual (KEX-20)
53.	B10-809-A	BM2.6 x 4		CRD-072	Owner's Manual (KEX-23)
				CRD-073	Owner's Manual (KEX-23)
54.		Holder	2.	CEA-253	Holder Kit
55.		Lever			
56.		Holder	2-1.	B10-875-A	BM4 x 6
57.	CCL-088	Feed through Capacitor	2-2.	B20-038-A	OTW10ø x 1.8t
58.	CNE-528	Clamper	3.	CHB-175	Styrofoam (1 set pair)
			4.	E36-622	Polyethylene Bag
59.		Connector	5.	CEA-314	Knob Kit
60.		Connector			
61.		Connector	5-1.	CAA-313	Knob
62.		Connector	5-2.	CAA-297	Knob
63.	BU-499	LED Array	5-3.	CAA-298	Knob
			6.	CEA-300	Accessory Kit
64.	TLR-102	LED	6-1.	CNC-975	Strap
65.	CSG-134	Switch			
66.		Connector	6-2.	CDE-437	Cord
67.	B08-204-A	Screw, M2 x 6	6-3.	CNV-769	Washer
68.		Spacer	6-4.	CEA-215	Screw Kit
			6-4-1.	CBA-028	Screw for Strap
69.	LN43SYP	LED	6-4-2.	B70-055-A	WN4ø x 4.5t
70.	TLG-102	LED			
71.	CEL-080	Lamp, 8V 60mA	6-4-3.	B20-013-A	SW4ø x 1t
72.		Holder	6-4-4.	B90-065-A	PSB5 x 16
73.		Cover	6-4-5.	B70-056-A	WN5ø x 5.3t
			6-4-6.	CND-646	FW10ø x 1t
74.	CXX-068	Display Unit	6-4-7.	CBN-016	N10ø x 3t
75.		Connector			
76.	CDE-458	Cord	7.	CEA-312	Panel (KEX-20)
77.	E21-007	Fuse, 0.5A		CEA-313	Panel (KEX-23)
78.	CDE-634	Cord	8.	CHB-577	Carton (KEX-20)
				CHB-579	Carton (KEX-23)
79.	CDE-636	Connector			
80.	CDE-633	Connector			
81.	CWG-071	Control Amp Unit			

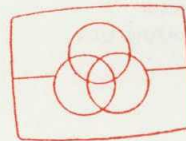

Free service manuals  
Gratis schema's

Digitized by

[www.freeservicemanuals.info](http://www.freeservicemanuals.info)

**PIONEER ELECTRONIC CORPORATION**

4-1, Meguro 1 chome, Meguro-ku, TOKYO, 153, JAPAN

**PIONEER ELECTRONICS OF AMERICA**

1925 E, Dominguez St. Long Beach, Calif. 90810

**PIONEER ELECTRONIC (EUROPE) N.V.**

Luithagen-Haven 9, 2030 Antwerp, Belgium

**PIONEER ELECTRONICS AUSTRALIA PTY. LTD.**

178-184 Boundary Road, Braeside, Victoria 3195, Australia